



# **DVD-V7300D**

**Industrial DVD Player**

**RS-232C**

## **COMMAND PROTOCOL MANUAL**

Version 1.01 Preliminary

January, 2000

Pioneer Corporation



## Table of Contents

<b>1.</b>	<b>INTRODUCTION .....</b>	<b>1</b>
<b>2.</b>	<b>INTERFACE .....</b>	<b>2</b>
2.1	Interface Connector .....	2
2.2	Serial Interface Pin Specification .....	2
2.3	Computer Control Functions .....	2
2.3.1	Serial Control (see Chapters 3, 4, 5 and 6).....	2
2.3.2	External Switch Control (see Chapter 9).....	3
2.3.3	External Power Control.....	3
<b>3.</b>	<b>SERIAL CONTROL.....</b>	<b>4</b>
3.1	Serial Interface Specifications.....	4
3.1.1	Signal Interface.....	4
3.1.2	Data Type.....	4
3.1.3	Data Transfer Speed (Baud Rate) .....	4
3.2	Communication with a Computer.....	4
3.3	Command and Status.....	6
3.4	Error Messages .....	8
3.5	Initial Setting.....	8
<b>4.</b>	<b>COMMAND STRUCTURE.....</b>	<b>9</b>
4.1	Command Mnemonic .....	11
4.2	Argument.....	11
4.3	Command String.....	12
4.4	Status Returns.....	12
4.5	Error Message.....	12
4.6	Request Status Return .....	13
4.7	Timing .....	13
4.8	Start timing under synchronized playback with several players.....	14
<b>5.</b>	<b>COMMAND DESCRIPTIONS .....</b>	<b>15</b>
5.1	Open .....	15
5.2	Close.....	15
5.3	Reject.....	15
5.4	Start.....	16
5.5	Play .....	16
5.6	Pause.....	17
5.7	Still (DVD, VCD) .....	17
5.8	Step Forward (DVD, VCD).....	17
5.9	Step Reverse (DVD).....	17
5.10	Scan Forward.....	19

5.11	Scan Reverse	19
5.12	Scan Stop	19
5.13	Multi-Speed Forward (DVD, VCD)	20
5.14	Multi-Speed Reverse (DVD)	20
5.15	Speed (DVD, VCD)	21
5.16	Search	22
5.17	Search & Play	23
5.18	Stop Marker	24
5.19	Lead-Out Symbol	26
5.20	Clear	26
5.21	Frame (DVD)	27
5.22	Block Number (CD, VCD)	27
5.23	Time (excludes discs without time codes)	28
5.24	Chapter (DVD)	28
5.25	Title (DVD)	28
5.26	Index (CD, VCD)	29
5.27	TRACK (CD, VCD)	29
5.28	Select Subtitle (DVD)	29
5.29	Select Audio (DVD)	30
5.30	Select Aspect	30
5.31	Select Angle (DVD)	30
5.32	Select Parental-Level (DVD)	31
5.33	Audio Control	31
5.34	Video Control	32
5.35	Display Control	32
5.36	Key Lock	34
5.37	Stack Group Set (DVD)	34
5.38	Barcode /Command Stack Play (DVD)	35
5.39	Video Blackboard Display (DVD)	35
5.40	Video Blackboard Clear	36
5.41	Blackboard / Stack Data Upload	36
5.42	Blackboard / Stack Data Download	43
5.43	Weekly Timer Data Upload	44
5.44	Weekly Timer Data Download	50
5.45	Text File Data Upload	51
<b>6.</b>	<b>CURRENT PLAYER CONDITION REQUEST Descriptions</b>	<b>53</b>
6.1	P-Block Number Request	53
6.2	Title/Track Number Request	53
6.3	Chapter Number Request (DVD)	54
6.4	Time Code Request	54

6.5	Index Number Request (CD, VCD).....	55
6.6	Frame Number Request (DVD) .....	55
6.7	Block Number Request (CD, VCD).....	56
6.8	Total Frame Request (DVD) .....	56
6.9	TOC Information Request (CD/VCD).....	56
6.10	Disc Region Code Request .....	57
6.11	DVD Disc Status Request.....	57
6.12	LD Disc Status Request (LB-compatible DVD) .....	58
6.13	CD Disc Status Request .....	59
6.14	Register A Set .....	59
6.15	Register B Set .....	61
6.16	Register D Set .....	62
6.17	Print Character .....	62
6.18	Clear Screen .....	63
6.19	Real Time Clock Set.....	64
6.20	Advanced Feature Menu Set .....	64
6.21	Communication Control Set.....	66
6.22	Player Active Mode Request.....	66
6.23	Player Model Name Request.....	67
6.24	Real Time Clock Request .....	67
6.25	Advanced Feature Menu Request .....	68
6.26	Player Region Code Request .....	68
6.27	CCR Mode Request .....	69
6.28	Input Number Request.....	69
6.29	Error Code Request.....	69
6.30	Input Unit Request.....	69
6.31	Input Barcode Data Request.....	70
6.32	Register A Request .....	70
6.33	Register B Request .....	71
6.34	Register D Request .....	72
6.35	Menu Call (DVD) .....	72
6.36	Numeric Button (DVD).....	73
6.37	Button Select (DVD) .....	73
6.38	Enter Button (DVD).....	74
6.39	Get Information (DVD).....	75
6.40	Memory Data Information.....	77
<b>7.</b>	<b>OPERATING MODES .....</b>	<b>79</b>
7.1	Open .....	79
7.2	Park.....	79
7.3	Setup.....	79

7.4	Random Access .....	79
7.5	Reject.....	80
<b>8.</b>	<b>DVD-V7300D INTERNAL REGISTERS.....</b>	<b>81</b>
8.1	Current Time/Frame .....	81
8.2	P-TIME .....	81
8.3	Current Title/Track (Current Chapter) .....	81
8.4	Current Index.....	81
8.5	Serial Digit Buffer.....	81
8.6	Remote Control Use Address Flag .....	81
8.7	Remote Control Digit Buffer .....	81
8.8	Remote Control Data Register.....	82
8.9	Laser Barcode Buffer.....	82
8.10	Serial Use Address Flag .....	82
8.11	Search Time/Frame.....	82
8.12	Search Title/Track (Search Chapter) .....	82
8.13	Search Index .....	82
8.14	Mark Time/Frame .....	82
8.15	Mark Title/Track (Mark Chapter) .....	83
8.16	Mark Index.....	83
8.17	Video Control.....	83
8.18	Audio Control.....	83
8.19	Display Control .....	83
8.20	Registers .....	83
<b>9.</b>	<b>EXTERNAL SWITCH CONTROL.....</b>	<b>85</b>
9.1	Function Assignment .....	85
9.2	Controller.....	87
9.2.1	Simple Circuit .....	88
9.2.2	Diode Matrix Circuit .....	88

## 1. INTRODUCTION

This document defines the RS-232C command protocol for the Pioneer DVD-V7300D Industrial DVD Player.

The DVD-V7300D is capable of playing DVD, CD and VCD discs. The device has three control methods; front panel, remote control or computer interface through the RS-232C serial port.

This manual addresses the various commands and precautions required when using the Pioneer DVD-V7300D player with a computer. Please refer to the *DVD-V7300D Operating Instructions* for details on operating the unit via the front panel and/or remote control.

Chapter Number	Description
Chapter 2	describes the Interface Connector Specifications and the computer control features of the DVD-V7300D
Chapter 3	discusses Baud Rate Settings, Interface Operation, Control Protocol, and Internal Operation via computer
Chapter 4	explains the Player Command Structure in detail
Chapter 5	reviews each command in detail
Chapter 6	defines Address and Player Condition requests
Chapter 7	relates to the various operating modes
Chapter 8	discusses the internal registers
Chapter 9	details the external switch control functions

NOTE: In this manual, a DVD disc containing a modified program from a current educational Laser Disc (LD) is handled as a Laser BarCode (LB) compatible DVD disc. The disc has two formats: CAV and CLV. However, the commands are not identical to the LD command set.

[This document defines Version1.01 for the Pioneer DVD-V7300D Industrial DVD Player.](#)

CAUTION: The material in this manual is subject to change without notice.

## 2. INTERFACE

### 2.1 Interface Connector

A computer may be connected to the DVD-V7300D using a 15-pin D-Sub connector (e.g., a JAE DALC-J15SAF connector with suitable plug such as the JAE DA-15PF-N) to the RS-232C serial port or to the parallel port.

The pins are identified below:

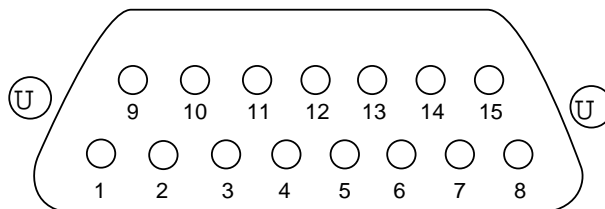

### 2.2 Serial Interface Pin Specification

Pin #	Terminal	Input/Output	Function
1	GND	--	ground
2	TxD	Output	send data
3	RxD	Input	receive data
4	DTR	Output	enable data receiving
5	POWER	Output	external power control
6	SW1	Input	
7	SW2	Input	
8	SW3	Input	
9	SW4	Input	
10	SW5	Input	
11	SW6	Input	
12	SW7	Input	
13	SW8	Input	
14	DLTST	Input	used only for servicing the unit – do not connect
15	V +8V	Output	used only for servicing the unit – do not connect

### 2.3 Computer Control Functions

#### 2.3.1 Serial Control (see Chapters 3, 4, 5 and 6)

The player and computer are based upon the RS-232C protocol and are connected through the TxD, RxD, DTR and GND terminals.

**2.3.2 External Switch Control (see Chapter 9)**

Control the player with the External Option Switches (SW#).

Please check the condition of the Key Lock. If the Key Lock is set (active), the player ignores the control. Please refer to the Key Lock command description.

**2.3.3 External Power Control**

Control the player's power with the Power Pin within the Interface Connector.

If the player detects a high signal throughput (100m/sec or more) during the Standby mode, the player powers ON. If the player detects the same signal during the Power ON mode, the player powers OFF and switches to the Standby mode.

The specifications for the Power pin are as follows:

Maximum Input Voltage	Less Than $\mu$ 12V
High Level Signal	More Than 4.5V
Low Level Signal	Less Than 0.5V

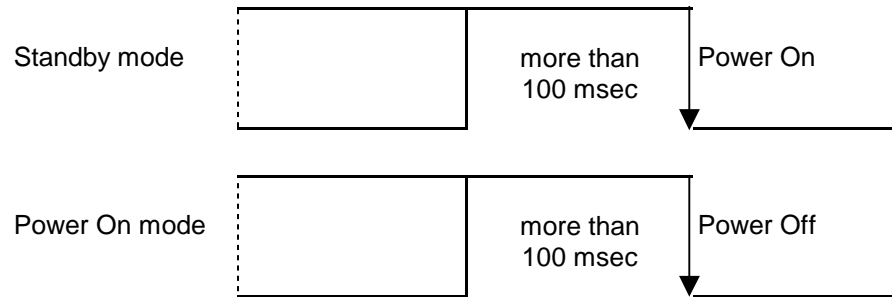

Please check the Key Lock condition. If the player is in the Key Lock mode, the player ignores the control. (Please refer to the Key Lock command description.)

### 3. SERIAL CONTROL

#### 3.1 Serial Interface Specifications

##### 3.1.1 Signal Interface

The signal interface is a standard RS-232C connection.

##### 3.1.2 Data Type

Data Length: 8 bit

Stop Bit: 1 bit

Parity bit: No Parity

##### 3.1.3 Data Transfer Speed (Baud Rate)

The data transfer speed may be set to either 4800 or 9600 baud through the Industrial player menu screen and/or with the Advanced Feature Menu Set command (please refer to the DVD-V7300D Operating Instructions and the Advanced Feature Menu Set command description).

NOTE: The factory default is 4800 baud; however, the player memorizes the transfer speed each time the power is cycled.

#### 3.2 Communication with a Computer

The DVD-V7300D communicates to the computer through the player's RS-232C port using pins 2 and 3 for communication and Pin 1 for grounding. Control or "handshaking" lines other than the TxD and RxD connections are not required. Please refer to the diagram below for clarification.

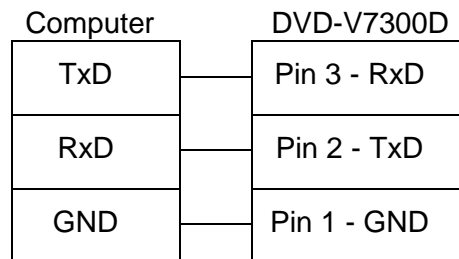

Some computers require the CTS port to be set to HIGH during communication. It is best to connect the CTS port on the computer to the DTR port on the player. During normal operation the player's DTR is set to HIGH thus the unit is able to receive a command at any time.

EX) Connection with the DOS/V Computer

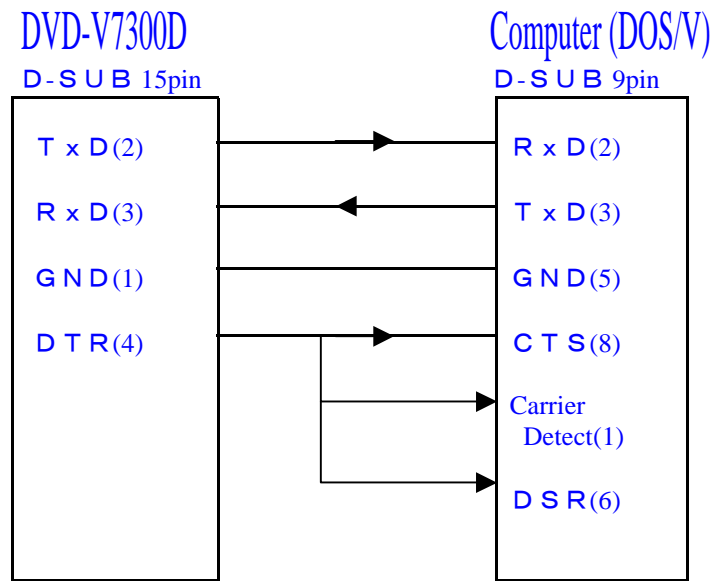

### 3.3 Command and Status

During normal operation, a computer transmits commands to a DVD-V7300D and the player responds with the status message, 'execution complete'.

#### Example

<u>COMPUTER</u>		<u>DVD-V7300D</u>
(1) "Search to Frame 1000"	⇒	(2) Search Execution
	⇐	(3) Complete
(4) "Play to Frame 2000"	⇒	(5) Play Execution
	⇐	(6) Complete

NOTE: The length of a command string is limited to 32 characters. Please refer to COMMAND STRUCTURE for additional information.

When using a computer to control the DVD-V7300D player, follow the command protocols listed below:

- ASCII characters are used for actual commands and status response
- Command mnemonic is expressed as two (2) ASCII characters
- Uppercase letters are recommended; however, usually there are no distinctions between the uppercase and lowercase letters
- Some commands require an argument (e.g. chapter number or speed)
- Use a command as the terminator of an argument

The player executes a command as soon as the carriage return <CR> is received. The <CR> acts as the command line terminator.

#### Example

CH<CR> : Set chapter for address mode  
10SE<CR> : Search to chapter 10

The player has a command buffer, which stores a command string of up to 32 characters in length.

#### Example

10SE 20PL<CR> : Search to chapter 10 then play to 20

The command string enters the buffer with the left character and continues sequentially from left to right. When the <CR> is entered, the commands are executed sequentially beginning with the first command in the buffer. In the example above, the first command is 10SE.

NOTE: The player ignores codes in the command string such as <SPACE> or <LF> (line feed) which do not affect the player's operation.

NOTE: Some commands, sent after a specialty command which includes an AUTOSTOP setting, (PL, MF, MR, etc.), cause the player to execute the new command before the AUTOSTOP is enacted (see Chapter 5, Command Descriptions).

When all the commands in a string have finished executing, the player transmits or *returns* the "complete" message.

The player returns an R after a command has been executed. This response is called the Automatic Status. The Automatic Status signals the computer program to send the next command. If this function is not used, the command processing time must be taken into consideration before the next command is sent.

If an error occurs, the player returns an error message such as E04. The message indicates an error has occurred as well as the type of error. Error messages are in the form of EXX where XX represents a 2-digit error code.

In some cases, an incorrect command sends the player to search within a non-recorded area and the player returns an error message. Use the Request Status function to determine the unit's current status (actual player hardware failures are rare).

Apply one of the following methods to reset the player after an error has occurred:

- Use ?P to determine the Active mode of the player
- Use ?X, ?W, ?M, ?H, ?H ?S to determine the player information, model name, clock time, player region code, the setting of Industrial Player Menu, etc.
- Use ?F, ?T, ?C, or ?R to determine the current frame, time, chapter, title/track number, respectively.
- Use ?V, ?D, ?K, ?G, ?Y, or ?Q to determine the disc information, disc type, total frame number, TOC information, etc.

The status functions are summarized below:

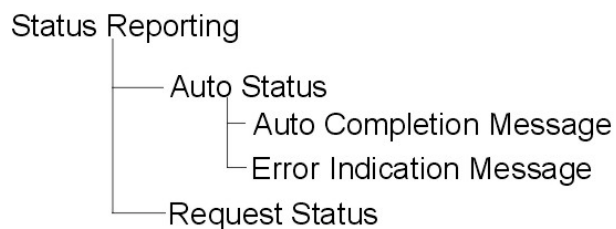

### 3.4 Error Messages

If an error occurs during a command execution, the player returns an error code. The table below lists each code with a description of the error:

Code	Message	Description
E00	Communication error	<i>Communication Line Error due to framing error or buffer overflow</i>
E04	Feature not available	<i>Non-Usable Function has been tried – either the command mnemonic is wrong or the command can not be used in this mode</i>
E06	Missing argument	<i>Correct parameter is not specified</i>
E11	Disc does not exist	<i>There is no disc in the tray</i>
E12	Search error	<i>Search address is missing Read error of Text File; (When the command [UU] is executed)</i>
E15	Picture stop	<i>Playback has been stopped by a picture stop code while in the Auto Play mode</i>
E16	Interrupt by other device	<i>The command(s) sent via the serial line were not executed before commands were sent from the front panel buttons and/or remote control Forced end of the data transfer while Text File sends to PC (When the command [UU] is executed)</i>
E99	Panic	<i>Unrecoverable Error occurred – possible that a disc cannot be loaded and/or playing does not continue</i>

### 3.5 Initial Setting

The following table provides the default internal register and switch settings. Take care to set each to the required parameters when creating an application program.

Register/Switch	Setting at Power ON
Key Lock	2 : If set to 2 power is OFF 0 : All other cases
Video Switch	1 : ON
Audio Switch	3 : Audio 1
Display Switch	0 : OFF
Address mode	1 : Time
Speed Parameter	30 : ½ Speed
CCR	3 : Mode 3
Register A	3 : Title/Chapter and Frame Display (DVD) Track/Time Display (CD, VCD)
Register B	0 : Normal Squelch
Register D	0 : CR

#### 4. COMMAND STRUCTURE

The DVD-V7300D supports the commands listed below.

COMMAND		SUPPORTING FORMATS			
Name	Mnemonic	DVD	LB comp. DVD	CD	VCD
Open	OP	X	X	X	X
Close	CO	X	X	X	X
Reject	RJ	X	X	X	X
Start	SA	X	X	X	X
Play	(adrs) PL	X	X	X	X
Pause	PA	X	X	X	X
Still	ST	X	X		X
Step Forward	SF	X	X		X
Step Reverse	SR	X	X		
Scan Forward	NF	X	X	X	X
Scan Reverse	NR	X	X	X	X
Scan Stop	NS	X	X	X	X
Multi-Speed Forward	(adrs) MF	X	X		X
Multi-Speed Reverse	(adrs) MR	X	X		
Speed	arg SP	X	X		X
Search	adrs SE	X	X	X	X
Search & Play *1	adrs SL	X	X	X	X
Stop Marker	adrs SM	X	X	X	X
Lead Out Symbol	LO	X	X	X	X
Clear	CL	X	X	X	X
Frame	FR	X	X		
Block Number	BK			X	X
Time	TM	X	X	X	X
Chapter	CH	X	X		
Title	TI	X	X		
Index	IX			X	X
Track	TR			X	X
Select Subtitle	arg SU	X	X		
Select Audio	arg AU	X	X		
Select Aspect	arg AP	X	X		
Select Angle	arg AG	X	X		
Select Parental-Level	arg PT	X	X		
Audio Control	arg AD	X	X	X	X
Video Control	arg VD	X	X	X	X
Display Control	arg DS	X	X	X	X
Key lock	arg KL	X	X	X	X
Stack Group Set	arg GP	X	X		
Barcode / Command Stack Play	arg BS	X	X		
Video Blackboard Display	arg VS	X	X		
Video Blackboard Clear	arg CB	X	X		
Blackboard/Stack Data Upload*1	BU	X	X	X	X
Blackboard/Stack Data Download*1	BD	X	X	X	X
Weekly Timer Data Upload*1	WU	X	X	X	X

COMMAND		SUPPORTING FORMATS			
Name	Mnemonic	DVD	LB comp. DVD	CD	VCD
Weekly Timer Data Download <sup>*1</sup>	WD	X	X	X	X
Text File Data Upload <sup>*1</sup>	UU	X	X		
Current Address Request	?A	X	X	X	X
Title/Track Number Request	?R	X	X	X	X
Chapter Number Request	?C	X	X		
Time Code Request	?T	X	X	X	X
Index Number Request	?I			X	X
Frame Number Request	?F	X	X		
Block Number Request	?B			X	X
Total Frame Request	?Y	X	X		
TOC Information Request	?Q			X	X
Disc Region Code Request	?G	X	X		
DVD Disc Status Request	?V	X	X		
LD Disc Status Request	?D		X		
CD Disc Status Request	?K			X	X
Register A Set (Display)	arg RA	X	X	X	X
Register B Set (Squelch)	arg RB	X	X	X	X
Register D Set (TxD Term) *1	arg RD	X	X	X	X
Print Character	arg PR	X	X	X	X
Clear Screen	CS	X	X	X	X
Real Time Clock Set	WW	X	X	X	X
Advanced Feature Menu Set *1	arg MS	X	X	X	X
Communication Control Set	arg CM	X	X	X	X
Player Active Mode Request	?P	X	X	X	X
Player Model Name Request	?X	X	X	X	X
Real Time Clock Request	?W	X	X	X	X
Advanced Feature Menu Request <sup>*1</sup>	?S	X	X	X	X
Player Region Code Request	?H	X	X	X	X
CCR Mode Request	?M	X	X	X	X
Input Number Request	?N	X	X	X	X
Error Code Request	?E	X	X	X	X
Input Unit Request	#I	X	X	X	X
Input Barcode Data Request	#B	X	X	X	X
Register A Request	\$A	X	X	X	X
Register B Request	\$B	X	X	X	X
Register D Request <sup>*1</sup>	\$D	X	X	X	X
Menu Call <sup>*2</sup>	arg MC	X	X		
Numeric Button <sup>*2</sup>	arg NB	X	X		
Button Select <sup>*2</sup>	arg CU	X	X		
ENTER Button <sup>*2</sup>	(arg) ET	X	X		
Get Information <sup>*2</sup>	arg GI	X	X		
Memory Data Upload	MU	X	X	X	X

NOTE: A command with an argument or address parameter is prefaced by arg (argument) or ards (address). If the arg or ards is in parentheses ( ), the parameter is optional.

## 4.1 Command Mnemonic

Each command is expressed as two (2) ASCII characters. There is no distinction between uppercase and lowercase letters except when the Character strings are in a PR command.

NOTE: Do not issue a command without a Text File Data Upload [UU], Reject [RJ] or Open [OP] sequence while the video text is displayed. A command issued without one of these sequences causes the player to return an error code E04.

## 4.2 Argument

An argument is expressed in either ASCII characters or ten digits and consists of either an address or an integer. A Control Register uses an integer value to set a specified value or condition.

If a command requires an argument, it is always placed before the command.

Example :  $N_1N_2N_3$   
 Minimum 000 ~ Maximum 300 (except MS command)  
 Minimum 000 ~ Maximum 520703 (Only MS command)

NOTE: If a command requires an argument but one is not supplied, the player returns an error message.

An Address can be a title, a chapter, a track, an index number, a frame number, or a time code depending upon how the address flag is set. The Address must not exceed ten characters and/or digits.

Address Type	Media Type	Format	Range (Min-Max)
Title Number	DVD	$N_1N_2$	0 ~ 99
Chapter Number	DVD	$N_1N_2$	0 ~ 99
Frame Number	DVD/VCD	$N_1N_2N_3N_4N_5N_6N_7^a$	0 ~ 1079999
Time Code	DVD	$N_1N_2N_3N_4N_5^b$	0 ~ 59959
	CD/VCD	$N_1N_2N_3N_4^c$	0 ~ 9959
Track Number	CD/VCD	$N_1N_2$	1 ~ 99
Index Number	CD/VCD	$N_1N_2$	1 ~ 99
Block Number	CD/VCD	$N_1N_2N_3N_4N_5N_6^d$	0 ~ 995974

### Integer:

Displays the parameters for commands (SU, AG, VS, MS, etc.) other than those listed above in 10 string ASCII characters

<sup>a</sup>  $N_aN_bN_c$  minutes  $N_dN_e$  seconds are calculated into frame number.

<sup>b</sup>  $N_1N_2N_3$  minutes  $N_4N_5$  seconds.

<sup>c</sup>  $N_1N_2$  minutes  $N_3N_4$  seconds.

<sup>d</sup>  $N_1N_2$  minutes  $N_3N_4$  seconds  $N_5N_6$  block.

### 4.3 Command String

A command string consists of multiple commands on one line. The maximum length of a command string is 32 characters. All command strings are terminated by the Carriage Return <CR> code (0DH hex).

Example : FR2000SE 2300PL<CR>

NOTE: The Real Time Clock Set [WW] , Print Character [PR], Blackboard/Stack Data Upload [BU], Blackboard/Stack Data Download [BD], Weekly Timer Data Upload [WU], Weekly Timer Data Download [WD], Text File Data Upload [UU] , Memory Data Upload [MU] commands should be assigned individually.

Once the <CR> termination command is added to the string, the command string is evaluated and executed from left to right in sequential order.

If an error occurs during the execution of a String, the remainder of the string following that command is not executed.

If a new command string is input before the execution of the current string is complete, the current string is aborted and the remaining commands are cleared.

To cancel a currently executing string, send the termination command <CR> alone.

If a new command without Text File Data Upload [UU,?\*,#\*,\$(Status Command)] is input while playing the current command stack, the remaining commands are cleared.

### 4.4 Status Returns

The completion message used in the Automatic Status is "R".

Example: R<CR>

### 4.5 Error Message

An error message is indicated by the letter E and followed by a two-character error code.

Example: EN<sub>1</sub>N<sub>2</sub><CR>

The error message occurs when the given command cannot be processed.



### 4.8 Start timing under synchronized playback with several players

To synchronize each playback to External Reference Sync Signal among several players, PL command should be issued after confirmed search completions in all players. The next chart indicates the timing for issuing PL command after the last player's search completion.

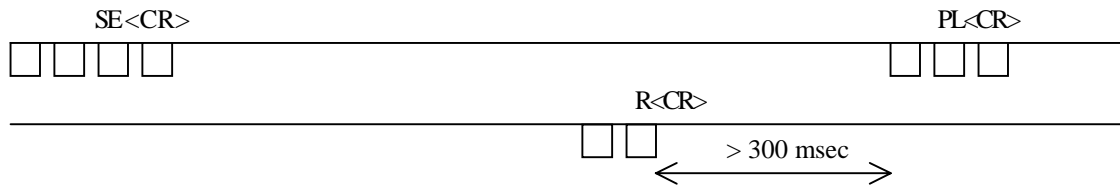

A player executes a search due to SE command, and it returns completion. There is a period that it can not accept PL command just after returned "R <CR>". So PL command should be issued at least more than 300ms after the last player's completion.

And also there is some other term before the synchronize playback start after issued PL command. The next chart explains this. If all the players receive PL command while waiting PLAY command period in the below, 3 TV signal fields should be wasting before the playback start.

In case a player receives PL command during Unspecified area in the below, the playback might be started 1st field just after, or it might be started 1st field after waited about 1 frame (4 fields). So this area is called Unspecified area.

Only PL command under external synchronization, is executed at the V sync timing.

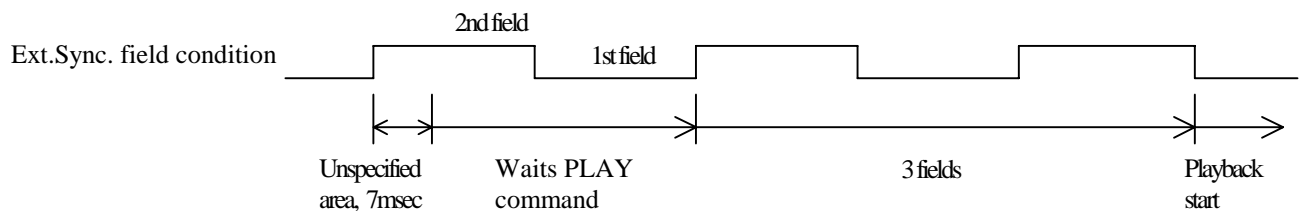

## 5. COMMAND DESCRIPTIONS

### 5.1 Open

Function : Door Opens (Tray Ejects)

Format : OP

Explanation : If the command is sent while the player is in the Park mode, the tray ejects and the player enters the Open mode. After the tray is ejected, the player returns the completed status message.

If the player is in any mode other than Open or Park, the disc stops, the player enters Open mode and the door opens.

If the player is already in Open mode, an error message is returned.

Execution:

String	Status Return	DVD-V7300D
OP<CR>	R<CR>	Park mode to Open mode

### 5.2 Close

Function : Door is closed (Tray is closed)

Format : CO

Explanation : If the command is sent while the player door is open, the door closes then the player enters the Park mode. After the door closes, the player returns the completed status message.

If the player is in any mode other than Open or if the player door is already closed, an error message is returned.

Execution :

String	Status Return	DVD-V7300D
CO<CR>	R<CR>	Open mode to Park mode

### 5.3 Reject

Function : Disc rotation stops

Format : RJ

Explanation : If the command is sent while the player is in Random Access mode or Setup mode, the player enters Reject mode and the disc stops

rotating. Once the disc completely stops, the player enters Park mode and returns the completed status message.

If the command is sent while the player is in Park mode, the player enters Open mode and the tray opens.

Execution :

String	Status Return	DVD-V7300D
RJ<CR>	R<CR>	Random Access mode to Park mode

NOTE: Sending a second Eject command causes the player to open the tray.

## 5.4 Start

Function : Disc rotation starts

Format : SA

Explanation : If the command is sent while the player is in Open, Park or Reject mode, the player immediately enters Setup mode and the disc begins rotating. The player is ready for playback when the device reaches the beginning of the program (DVD, CD or VCD disc pauses or stills at the first track). The player returns the completed status when the disc pauses or stills.

If the player receives the command while playing a menu, the player returns an error message. However, if the disc program does not allow new commands once playback begins, the player ignores the command.

Execution :

String	Status Return	DVD-V7300D
SA<CR>	R<CR>	Park mode to Pause mode
SA<CR>	E11<CR>	Open mode to Park mode <i>Error – No disc in tray</i>

## 5.5 Play

Function : Pictures and sound are reproduced (Option - Auto Stop)

Format : (Address)PL

Explanation : If the command is sent while the player is in Open, Park, or Reject mode, a DVD disc plays according to the menu selection or from the first title if a menu is absent. A CD/VCD disc plays from the first track. The player returns the completed status message after playback begins.

If the player is in Random Access mode when the Play command is sent, the player enters Play mode and returns the completed status message. The Play is the only mode in which audio plays back simultaneously with video.

If an address is specified, an Auto Stop occurs on the selected sequence. The specified address is written as a Mark Frame or Mark Time and is compared with the current address. If the current address matches the specified address, the player enters Still mode and returns the completed status message.

The Auto Stop command is canceled if another command is sent before the player reaches the specified address. When this occurs, the player enters normal Play mode (the Stop Marker command is similar in function to Auto Stop).

If a Picture Stop code is detected before the player reaches the specified address, the player enters Still mode and returns an error message. However, if the disc program does not allow a stop, the player ignores the command and it may return the error message. [Also, when the difference between the current address and the chosen option address is less than 24 frames, the marker setting error E06 will not be returned, nor will playmode resume](#)

The available address modes are listed below:

Address Mode	DVD	LB-compatible DVD	CD	VCD
FR (frame)	X	X		
TM (time)	X	X	X	X
CH (chapter)	X	X		
TI (title)	X	X		
BK (block)			X	
IX (index)			X	X
TR (track)			X	X

It is possible that an Auto Stop command within a VCD Block Number Address misses the specified address. Depending upon when the command is sent, a playback address may be missed by a maximum of ten-blocks.

Execution :

String	Status Return	DVD-V7300D
PL<CR>	R<CR>	Park mode to Play mode
TM0325PL<CR>	<i>plays to 3 minutes 25 seconds</i>	Pause mode to Play mode
	R<CR>	Play mode to Still mode

## 5.6 Pause

Function : Playback ceases temporarily

Format : PA

Explanation : If the command is sent while the player is in Random Access mode, the pause occurs at the current disc location. The player returns the completed status message immediately.

In Pause mode, Still and Video Squelch are ACTIVE. However, if the disc program does not allow a pause, the player ignores the command and returns the error message (E04).

Execution :

String	Status Return	DVD-V7300D
PA<CR>	R<CR>	Play mode to Pause mode
PL<CR>	R<CR>	Return to Play mode

## 5.7 Still (DVD, VCD)

Function : Playback is stopped on a selected visual

Format : ST

Explanation : If the command is sent while the player is in Random Access mode, playback stops at the current disc position and the player enters Still mode. The player returns the completed status message immediately. However, if the disc program does not allow a pause, the player ignores the command and returns the error message (E04).

Execution :

String	Status Return	DVD-V7300D
ST<CR>	R<CR>	Play mode to Still mode
PL<CR>	R<CR>	Return to Play mode

## 5.8 Step Forward (DVD, VCD)

## 5.9 Step Reverse (DVD)

Function : Playback is moved forward or in reverse by one frame

Format : SF (Step Forward)

SR (Step Reverse)

Explanation : If the command is sent while the player is in Random Access mode, the picture moves one frame forward or one frame in reverse. After the move is accomplished, the player enters Still mode and returns the *completed* message.

If the disc program does not allow a pause, the player ignores the command and returns the error message (E04).

NOTE: If REV/STEP/REV PLAY in ADV.SETUP MENU is setting [VOBU], A single DVD Step Reverse is equal to between 15 and 30 frames.

If REV/STEP/REV PLAY in ADV.SETUP MENU is setting [Frame], A single DVD Step Reverse is equal to 1 frame.

NOTE: A Video CD disc does not support the Step Reverse command

Execution :

String	Status Return	DVD-V7300D
SF<CR>	<i>Moves 1 frame forward</i>	Play mode
	R<CR>	Still mode
SRSRSR<CR>	<i>Moves 3 frames backwards</i>	Play mode
	R<CR>	Still mode

### 5.10 Scan Forward

### 5.11 Scan Reverse

### 5.12 Scan Stop

Function : Playback moves quickly forward or in reverse

Format : NF (Quick Forward scanning of the disc)

NR (Quick Reverse scanning of the disc)

NS (Stop Quick Forward scanning and return to normal playback)

Explanation : If the command is sent while the player is in Random Access mode, the screen proceeds forward (NF) or in reverse (NR) quickly. When scanning is finished, the player resumes the Random Access mode and returns the completed status message.

If the SCAN command is sent while the player is in fast forward or reverse playback, the player enters Scan mode.

Once the NS command is sent, the player resets to the normal Playback mode and returns the completed status message.

Execution :

String	Status Return	DVD-V7300D
NF<CR> or NR<CR>	R<CR>	Play mode to Scan mode
NS<CR>	R<CR>	Return to Play mode

### 5.13 Multi-Speed Forward (DVD, VCD)

### 5.14 Multi-Speed Reverse (DVD)

Function : Playback occurs at the speed specified in the Speed Register  
(Option - Auto Stop)

Format : (Address)MF (Multi-Speed Forward)  
(Address)MR (Multi-Speed Reverse) (Address > 0)

Explanation : If the player is in Random Access mode when the command is executed, the player enters Multi-Speed mode and returns the completed status message immediately.

While in Multi-Speed mode, pictures are reproduced at the speed specified by the Speed Register. No audio tracks are played during Multi-Speed playback.

NOTE: These speeds are approximate values only.

If an address is specified, an Auto Stop occurs on the selected sequence. The specified address is written as a Mark Frame or Mark Time and is compared with the current address. If the current address matches the specified address, the player enters Pause or Still mode and returns the completed status message. This command functions in a similar manner as the Stop Marker command.

If another command is issued before the player reaches the specified Address, the Auto Stop command is canceled and the player enters normal Multi-Speed mode. However, if the disc program does not allow a pause, the player ignores the command.

If REV/STEP/REV PLAY in ADV.SETUP MENU is setting [FRAME], multi-speed reverse is 1/1,1/2,1/4,1/8,1/16,STEP1 speed in DVD. And If REV/STEP/REV PLAY in ADV.SETUP MENU is setting [VOBU], multi-speed reverse is SLOW only in DVD. VCD offers 1/2 to 1/16 speed forward only.

Sometimes an Auto Stop command within a Multi-Speed command misses the specific address. Depending upon when the command is sent, a playback address may be missed by a maximum of ten-blocks.

DVD reverse direction playback speed can be set to 1/1, 1/2, 1/4, 1/8, 1/16 step 1 (when REV STEP/REV PLAY is set as FRAME in ADV setup). Also playback is possible at a set slow speed. (when set in VOB setup)  
 VCD forward speeds can be set between 1/2-1/16, but can not be set to reverse direction playback. Also depending on the set speed, the addresses can not be read on a frame by frame basis, playback may end 10+ frames early.

The available address modes in each disc type are listed below:

Address Mode	DVD	LB-compatible DVD	CD	VCD
FR (frame)	X	X		
TM (time)	X	X		X
CH (chapter)	X	X		
TI (title)				
BK (block)				
IX (index)				X
TR (track)				X

When playing back a VCD disc, sometimes an Auto Stop command within a Block Number address misses the specified address. Depending upon when the command is sent, a playback address may be missed by a maximum of ten-blocks.

Execution :

String	Status Return	DVD-V7300D
MF<CR>	R<CR>	Play to Multi-Speed mode
TM0325MF<CR>	<i>plays to 3 min. 25 secs</i> R<CR>	Pause to Multi-Speed mode Pause mode

### 5.15 Speed (DVD, VCD)

Function : Specifies the speed for Multi-Speed playback

Format : Integer SP

Explanation : The command rewrites the contents of the Speed Register and returns the completed status message. The current mode of the player does not change.

The speed parameter indicates the number of fields per second. The range is 0 through 90 with a default value of 15 fields per second. The relationship between the integer, speed parameter and the actual speed of the player is as follows:

Integer	Speed Parameter	Speed
60	46~90	1/1
30	23~45	1/2
15	12~22	1/4
7	6~11	1/8
4	3~5	1/16
1	0~2	Step1

NOTE: The VCD Forward speeds: 1/2 –1/16 is available. Reverse speed is not available.

Execution :

String	Status Return	DVD-V7300D
4SPMF<CR>	R<CR>	Play mode to 1/16 speed forward
30SP<CR>	R<CR>	Multi-Speed to 1/2 Multi-Speed
4SPMR<CR>	R<CR>	Multi-Speed to 1/16 Reverse

## 5.16 Search

Function : Search to specified address

Format : Address SE

Explanation : The specified address is written into the Search Register in accordance with the current search address mode.

When the Search command is sent to the player, the specified address is compared with the current address. The pick-up is moved so that the difference becomes 0.

Upon reaching the specified address, the player enters the Pause mode in CD and the Still mode in the others types of discs. The player then returns the completed status message. If the player misses the specified address or can not find it, an error message (E06 or E12) is returned. However, if the disc program disallows a time or chapter search, the player ignores the command and an error message (E04) is returned. In addition, if the disc program does not allow a pause, the player ignores the command.

The available address modes are listed below:

Address Mode	DVD	LB-compatible DVD	CD	VCD
FR (frame)	X	X		
TM (time)	X	X	X	X
CH (chapter)	X	X		
TI (title)	X	X		
BK (block)			X	
IX (index)			X	
TR (track)			X	X

Sometimes, an Auto Stop command within a VCD Block Number Address misses the specified address. Depending upon when the command is sent, a playback address may be missed by a maximum of ten-blocks.

Execution :

String	Status Return	DVD-V7300D
FR4500SE<CR>	Search to frame 4500	Play mode Address Mode set = Frame Still mode (DVD)
	R<CR>	
CH5SE<CR>	Search to chapter 5	Play mode Address mode set = Chapter Still mode
	R<CR>	
TR2SE<CR>	Searches to track 2	Play mode Address mode set = Track Still mode (VCD)
	R<CR>	
IX902SE<CR>	Search to index 2, track 9	Play mode Address mode set = Index Pause mode (CD)
	R<CR>	

## 5.17 Search & Play

Function : Searches to specified address and starts to play immediately

Format : (Address) SL

Explanation : The specified address is written into an appropriate register according to the Address. Then the player compares the address with the current address. The pick-up moves so that the difference becomes 0.

The player plays a disc immediately after reaching the specific address. In case the player misses or fails to locate the address, it returns an error code (E06 or E12). If Frame is selected in Address Mode, the player ignores the command.

The available address modes are listed below:

Address Mode	DVD	LB-compatible DVD	CD	VCD
FR (frame)				
TM (time)	X	X	X	X
CH (chapter)	X	X		
TI (title)	X	X		
BK (block)			X	
IX (index)			X	
TR (track)			X	X

Execution :

String	Status Return	DVD-V7300D
CH5SL<CR>		Play mode
	R<CR>	Search Chapter 5 and Play
TR2SL<CR>		Search Track 2 and Play
	R<CR>	Search Track 2 and Play

## 5.18 Stop Marker

Function : Stop Marker is set to the specified address

Format : Address SM

Explanation : The specified address is written into the Mark-Frame Register or Mark-Chapter Register in accordance with the address specification flag. The player returns the completed status message immediately.

The Stop Marker is cleared when the player reaches the marked address via a Play command, a Multi-Speed operation or other action. The player enters the Pause mode (CD) or the Still mode (other disc types) with no messages returned. However, if the disc program does not allow a pause, the player ignores the command.

A Time Code or Chapter Number request notes whether or not the player reached a marked address. The Clear and Reject commands remove the marker.

Also, when the difference between the current address and the chosen option address is less than 24 frames, the marker setting error E06 will not be returned, nor will playmode resume

The Stop Marker is the same in functionality as the Play or Multi-Speed Auto Stop commands. The primary difference is when the player returns the status message. The Multi-Speed Auto Stop command returns the completed status message when the player reaches the marked address while the Stop Marker command returns the message as soon as the Stop Marker is set.

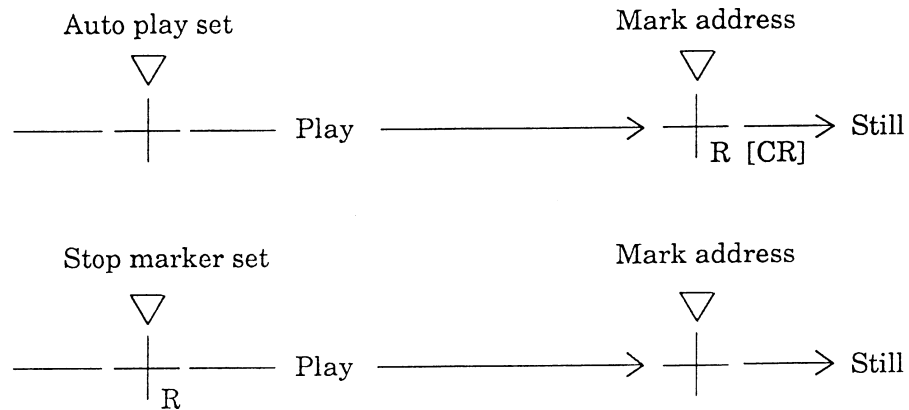

The available address modes are listed below:

Address Mode	DVD	LB-compatible DVD	CD	VCD
FR (frame)	X	X		
TM (time)	X	X	X	X
CH (chapter)	X	X		
TI (title)	X	X		
BK (block)			X	
IX (index)			X	X
TR (track)			X	X

Sometimes, an Auto Stop command within a VCD Block Number Address misses the specified address. Depending upon when the command is sent, a playback address may be missed by a maximum of a few ten-blocks.

Execution :

String	Status Return	DVD-V7300D
TM0325SMPL<CR>	R<CR>	Pause mode to Play mode
MF<CR>	R<CR>	Multi-Speed mode
PL<CR>	R<CR>	Play mode plays to 3 minutes 25 seconds ⇒ Still mode

### 5.19 Lead-Out Symbol

Function : Lead-Out is set for an address

Format : LO Command <CR>

Explanation : This symbol can be used in place of a time code or a frame number as a target address for the Search or Auto Stop functions.

If the player has read the Table of Contents (TOC) from a disc, the Lead-Out Address or a Frame Number can be translated into the time of a lead-out.

The Lead-Out Search command on a CD or VCD disc stops the player at the end of a program area prior to the read-out area while the Lead-Out Search command on a DVD disc stops the player at the end of this title.

NOTE: On a VCD disc, the search address is set several seconds prior to the lead-out point because the Lead-Out command requires the player to read video data in advance.

Execution :

String	Status Return	DVD-V7300D
LOSE<CR>	R<CR>	Search to Still mode
?T<CR>	13642<CR>	<i>Time code in program end area</i>
LOPL<CR>	R<CR>	<i>Continue playing to lead-out and then return R&lt;CR&gt;</i>

### 5.20 Clear

Function : Clears the digit buffer or mode

Format : CL

Explanation : The command clears the digit buffer content (input value) and returns the completed status message immediately.

The command releases the Auto Stop or the Stop Marker modes and returns the completed status message immediately. After the commands are released, the player begins normal playback. But the command does not release the Multi Speed command.

The Clear command releases the Repeat mode and erases the Command Stack selections.

Execution :

String	Status Return	DVD-V7300D
FR22000CL2300SE<CR>	<i>searches to frame 2300</i>	Play mode
	R<CR>	Still mode
TM500SMPL<CR>	R<CR>	Play with Stop Marker
CL<CR>	R<CR>	<i>Stop Marker is released and player begins normal playback</i>

## 5.21 Frame (DVD)

Function : Address specification flag is set to frame

Format : FR

Explanation : Address assignment proceeds frame by frame. All subsequent addresses are handled as a frame number.

Execution :

String	Status Return	DVD-V7300D
FR123450SE<CR>	<i>searches to frame 123450</i>	Play to Search mode
	R<CR>	Still mode

*[maximum number of frames is 7-digits in length (#####)]*

## 5.22 Block Number (CD)

Function : Address specification flag is set to block

Format : BK

Explanation : Address assignment proceeds by block. All subsequent addresses are handled as a block number.

The Block refers to a physical block within a CD . The physical block consists of 75 frames or blocks per second (different from traditional Video Frames).

The player is unable to search to a Block Number on VCD disc.  
(please refer to section 8.10 Serial Use Address Flag)

Execution :

String	Status Return	DVD-V7300D
BK243020SE<CR>	<i>searches to 24 min, 30 secs, 20 blocks</i>	Play to Search mode
	R<CR>	Pause mode

**5.23 Time (excludes discs without time codes)**

Function : Address specification flag is set to time

Format : TM

Explanation : Address assignment proceeds by time code. All subsequent addresses are handled as a time code.

(please refer to section 8.10 Serial Use Address Flag)

Execution :

String	Status Return	DVD-V7300D
TM12345SE<CR>	<i>search to 123 min, 45 secs</i>	Play to Search mode
	R<CR>	Still mode

[maximum number of frames is 7-digits in length (#####)]

**5.24 Chapter (DVD)**

Function : Address flag is set to chapter

Format : CH

Explanation : Address assignment proceeds by chapter number. All subsequent addresses are handled as a chapter number. If the chapter number is not recorded on the disc, an error message is returned.

(please refer to section 8.10 Serial Use Address Flag)

Execution :

String	Status Return	DVD-V7300D
CH23SE<CR>	<i>search to chapter 23</i>	Play to Search mode
	R<CR>	Still mode

**5.25 Title (DVD)**

Function : Address flag is set to title

Format : TI

Explanation : Address assignment proceeds by title. All subsequent addresses are handled as a title number.

(please refer to section 8.10 Serial Use Address Flag)

Execution :

String	Status Return	DVD-V7300D
TI5SE<CR>	<i>search to Title 5</i>	Play to Search mode
	R<CR>	Still mode

**5.26 Index (CD)**

Function : Address flag is set to index

Format : IX

Explanation : Address assignment proceeds by index. All subsequent addresses are handled as an index number.

(please refer to 8.10 Serial Use Address Flag)

Execution :

String	Status Return	DVD-V7300D
IX1204SE<CR>	<i>search to index 4, track 12</i>	Play to Search mode
	R<CR>	Pause mode (CD)

**5.27 TRACK (CD, VCD)**

Function : Address flag is set to track

Format : TR

Explanation : Address assignment proceeds by track. All subsequent addresses are handled as a track number.

(please refer to section 8.10 Serial Use Address Flag)

Execution :

String	Status Return	DVD-V7300D
TR15SE<CR>	<i>search to track 15</i>	Play to Search mode
	R<CR>	Pause mode

**5.28 Select Subtitle (DVD)**

Function : Set Subtitle

Format : Integer SU

Explanation : The command sets the subtitle (caption). The player allows up to 32 subtitles for playback. If an unavailable track is selected, the player returns an E06 error message.

Execution :

String	Status Return	DVD-V7300D
		Play mode
0SU<CR>	R<CR>	Subtitle off

### 5.29 Select Audio (DVD)

Function : Select Audio

Format : Integer AU

Explanation : The command selects the audio channel (audio track). The player allows up to 8 audio channels for playback. If an unavailable track is selected, the player returns an E06 error message.

NOTE: If the setting is 0, the audio mute is ON.

Execution :

String	Status Return	DVD-V7300D
0AU<CR>	R<CR>	Play mode Audio mute On

### 5.30 Select Aspect(DVD)

Format : Select Aspect Ratio

Function : Integer AP

Explanation : The command sets the Aspect Ratio for playback. The three ratios are Pan & Scan, Letter Box or Wide. If a disc does not offer video output options, the player returns an E04 error message.

Argument	Aspect Ratio (Video output)
1	Pan & Scan
2	Letter Box
3	Wide

Execution :

AGUMENT	ASPECT
1	PAN&SCAN
2	LETTER BOX
3	WIDE

### 5.31 Select Angle (DVD)

Function : Select Angle

Format : Integer AG

Explanation : The command selects a viewing angle. The player allows up to 9 angles for playback. If an unavailable angle is selected, the player returns an error message (E04 or E06).

## Execution :

String	Status Return	DVD-V7300D
2AG<CR>	R<CR>	Play mode Angle change

**5.32 Select Parental-Level (DVD)**

Function : Set Parental Level

Format : Integer PT

Explanation : The command sets the parental level. The player allows up to 8 levels for playback. If an unavailable level is selected, the player returns an error message.

Note: [When DVD is setting and stopping, this command is available. If not this Situation, the player returns an error message.](#)

**5.33 Audio Control (DVD,CD,VCD)**

Function : Control Audio Output

Format : Integer AD

Explanation : The command allows changes to the audio output from the default value (7) then returns the completed status message. The player resets to the default value when the tray opens or when the power cycles.

NOTE: The player automatically resets the audio control to 3 (Audio 1), when it is powered ON.

The output channel assignment for each integer (argument) is listed below:

Argument	DVD <sup>6e</sup>	CD <sup>1</sup>	VCD
0	Off	Off	Off
1	Audio 2	---	---
2	Audio 3	---	---
3	Audio 1	---	---
4	Off	Off	Off
5	Audio 5	L	L
6	Audio 6	R	R
7	Audio 4	Stereo	Stereo

<sup>e</sup> Includes LB compatible DVD

Execution :

String	Status Return	DVD-V7300D
5AD<CR>	R<CR>	audio output = Stereo becomes audio output = Audio 5, L-ch

### 5.34 Video Control

Function : Video switch is turned ON / OFF

Format : Integer VD

Explanation : The command switches the video output ON or OFF then returns the completed status message. The default is 1 (video switch ON).

The squelch switch adjusts the video output when the video control is ON (during playback). If the player is in Park, Search or Pause mode, the video squelch is OFF and the color background is displayed.

When the Video Control is set to 0 (OFF), the video is squelched at all times.

Argument	Function	Video Switch
0	OFF	OFF
1	ON	ON

Execution :

String	Status Return	DVD-V7300D
0VD<CR>	R<CR>	Video Switch = ON to Video Switch = OFF

### 5.35 Display Control

Function : Character display is turned ON / OFF

Format : Integer DS

Explanation : The player rewrites the Display Control Register (argument) then returns the completed status message. The default register value is 0 (display switched OFF). Arguments can display User's Area Characters, Title Number, Time Code, Chapter Number and Audio Output information.

Display changes are restricted when Argument 1 is set through the 232C connection. The remote control is blocked from changing the on-screen display.

[A 2 Frame difference between the frame number display and actual frame number may occur during playback of movies](#)

Argument	Function
0	OFF
1	Displays user's area that is set by Register A
2	Title, chapter, track number, length of play, etc.
3	Play time or remain time of each chapter
4	Play time or remain time of each title
5	Audio and Subtitle information and Transfer rate etc
6	Add frame number to ARG.2 display

Execution :

String	Status Return	DVD-V7300D
1DS<CR>	R<CR>	Display Switch = OFF to Display Switch = ON <i>Display condition is set on Register A</i>
3DS<CR>	R<CR>	Display condition = 3
DS<CR>	R<CR>	Display Switch = OFF

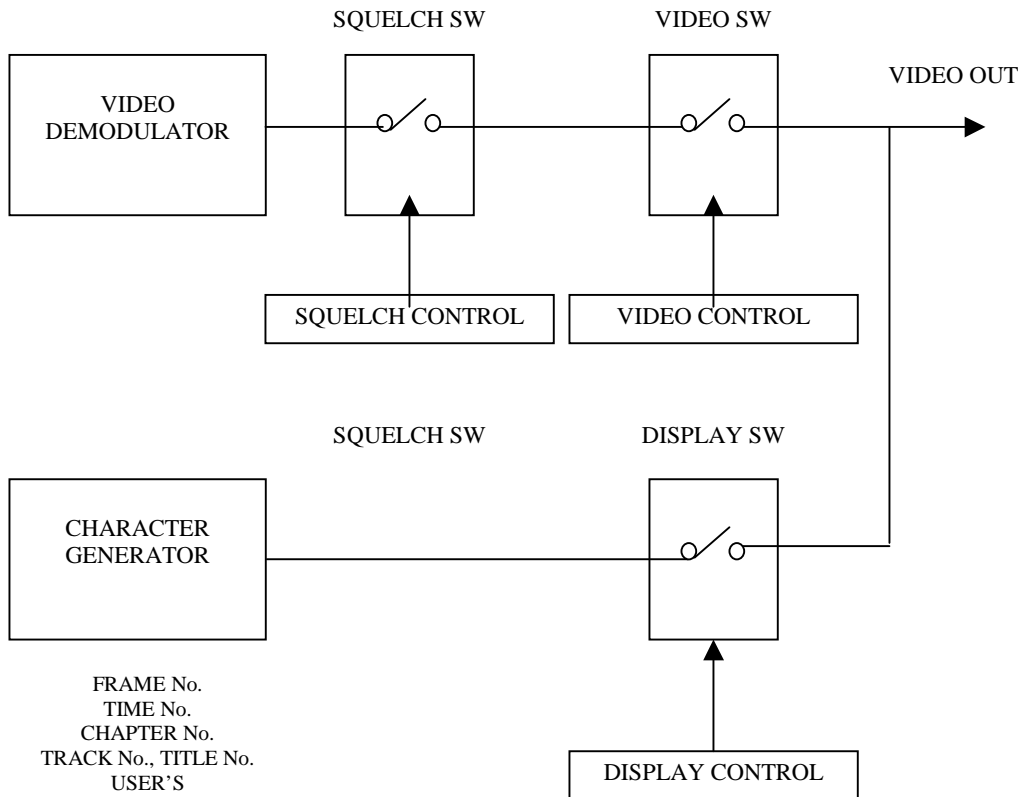

### 5.36 Key Lock

Function : The key lock switch is turned ON / OFF

Format : Integer KL

Explanation : The command enables/disables the remote control and access via the front panel buttons. The default value is 0 (OFF) thus the player is unlocked.

If the key lock switch is set to 1, all buttons (front panel and remote control) including the External switch control, mouse control and the power control are disabled. Use this setting for a PC-controlled player to lessen interference from outside sources such as remote controls.

If the key lock switch is set to 2, only the tray open button/key is disabled and the OP command no longer controls the tray. Thus, after powering OFF the player, the locked tray protects the disc from unauthorized personnel.

Argument	Function
0	Unlock
1	Locks all keys include power
2	Locks only tray open

Execution :

String	Status Return	DVD-V7300D
1KL<CR>	R<CR>	Key Lock ON
OKL<CR>	R<CR>	Key Lock OFF (unlocked)
2KL<CR>	R<CR>	Tray Open Lock ON

### 5.37 Stack Group Set (DVD)

Function : Set the Stack Group (Video Blackboard Stack or Barcode / Command Stack)

Format : Integer GP

Explanation : The command sets the stack group (Video Blackboard Stack or Barcode/Command Stack) for execution or access. It is added in conjunction with the [BS] (BARCODE/COMMAND STACK PLAY) or the [VS] (VIDEO BLACKBOARD DISPLAY) command.

1 to 300, decimal system integer number is used in its argument.

### 5.38 Barcode /Command Stack Play (DVD)

Function : Execute Barcode/Command Stack

Format : Integer BS

Explanation : The command executes the Barcode/Command stack group after the GP command specifies the group number.

The player returns an E06 error message if the BS command is issued with an unknown or unspecified group number or [Step](#).

1 to 300, decimal system integer number is used in its argument.

Execution :

String	Status Return	DVD-V7300D
25GP16BS<CR>	R<CR>	Execute from group 25/step 16

### 5.39 Video Blackboard Display (DVD)

Function : Execute Video Blackboard Display (displays a graphic or character)

Format : Integer VS

Explanation : The command presents the video blackboard display after the GP command specifies the group number. If the option is set to 0, the group graphics or characters are displayed on the screen. Settings between 1 and 300 cause the player to display the specified graphic or character only.

Errpr E06 is returned from a player in case VS command is issued with unknown group number that is not specified by user.

1 to 300, decimal system integer number is used in its argument.

NOTE: Graphics or characters display automatically if the drawing/text is flagged with the Auto Display command.

Execution :

String	Status Return	DVD-V7300D
25GPOVS<CR>	R<CR>	If Group 25 is available then it displays automatically
25GP32VS<CR>	R<CR>	Displays step 32 (graphic or character) from Group 25

### 5.40 Video Blackboard Clear

Function : Clears Video Blackboard Display

Format : CB

Explanation : The command clears all displayed graphics and characters from the video blackboard display. Following execution of this command, all following steps are canceled.

Execution :

String	Status Return	DVD-V7300D
CB<CR>	R<CR>	Clear the video blackboard display

### 5.41 Blackboard / Stack Data Upload

Function : Reads the data in the player: Blackboard data, Barcode data, Stack data

Format : BU

Explanation : The player sends the data to the computer after the command while it is Park mode.

The Communication flows as shown below.

(N=9320)

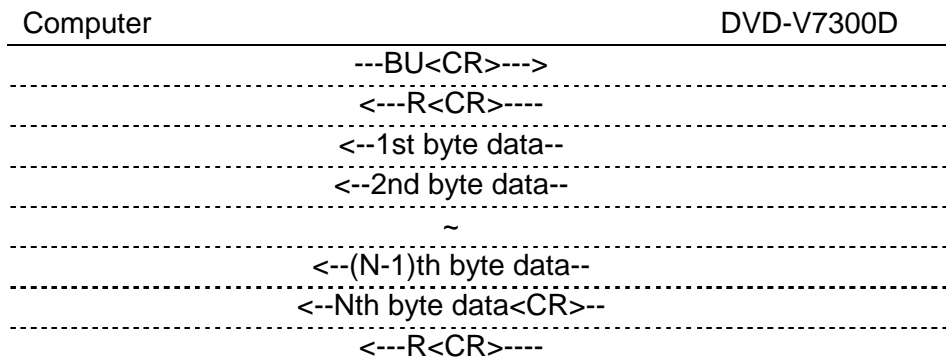

Format of the data:

BP	Contents	Numbers of bytes
0 - 1	(1) Total number of the transfer data (fixed number = 2468H)	2 bytes
2 - 3	(2) The version of this data format (fixed value)	2 bytes

4 - 5	(3) Barcode #1 Search Pointer	2 bytes
6 - 7	Barcode #2 Search Pointer	2 bytes
~	~	~
600 - 601	Barcode #299 Search Pointer	2 bytes
602 - 603	Barcode #300 Search Pointer	2 bytes
604 - 605	(4) Number of Next Barcode Data	2 bytes
606 - 607	(5) Number of Next Barcode Group	2 bytes
608 - 609	(6) Blackboard #1 Search Pointer	2 bytes
610 - 611	Blackboard #2 Search Pointer	2 bytes
~	~	~
1204 - 1205	Blackboard #299 Search Pointer	2 bytes
1206 - 1207	Blackboard #300 Search Pointer	2 bytes
1208 - 1209	(7) Number of Next Blackboard Data	2 bytes
1210 - 1211	(8) Number of Next Blackboard Group	2 bytes
1212 - 1213	(9) Number of Next Blackboard Unit	2 bytes
1214 - 1215	(10) Next Data Address	2 bytes
1216 - 9315	(11) Barcode & Blackboard Data	8100 bytes
9316 - 9319	(12) Checksum	4 bytes

## (1) Fixed data:

indicates the total data bytes of this transfer with HEX digits

2468H = 9320

## (2) Fixed data:

indicates the version of this data format is (0100H) now

To avoid errors, this code must remain intact. Do not change any digits within this code.

## (3)

indicates the head address of the #Nth Barcode / Command Stack data

The head address is a relative address. The base address is (BP = 1216) and (BP = 1216) is the head byte of the Barcode & Blackboard Data in this format.

(N = 1 ~ 300)

If the data of #Nths is invalid, it shows (ffffH).

## (4)

indicates the numbers of the registered Barcode / Command Stacks

It is available from 0 to 299 in a HEX digit format.

## (5)

indicates the group number of the next Barcode / Command Stack

It is available from 0 to 299 in a HEX digit format.

- (6)  
 indicates the head address of the #Nth Blackboard data  
 The head address is a relative address. The base address is (BP = 1216)  
 and (BP = 1216) is the head byte of the Barcode & Blackboard Data in this  
 format.  
 (N = 1 ~ 300)  
 If the data of #Nths is invalid, it shows (ffffH).
- (7)  
 indicates the numbers of the registered Picture / Text  
 It is available from 0 to 299 in a HEX digit format.
- (8)  
 indicates the group number of the next Picture / Text  
 It is available from 0 to 299 in a HEX digit format.
- (9)  
 indicates the number of the next Picture / Text  
 It is available from 0 to 299 in s HEX digit format.
- (10)  
 indicates the head address of the next Barcode / Command Stack data or  
 Picture / Text data  
 The head address is a relative address. The base address is (BP = 1216)  
 and (BP = 1216) is the head byte of the Barcode & Blackboard Data in this  
 format.
- (11)  
 Comprises the body of the data
- (12)  
 checksum of the data that indicates the result of adding up BP 0 through BP  
 9315 and shows in HEX (double word) format.

Format of Barcode / Command Stack data in the data:

The length of Barcode / Command Stack data is 16 bytes. This is a fixed  
 length. Each byte is made up of aH (upper nibble) and one digit of the  
 Barcode Command (lower nibble). The Barcode Command length is available  
 up to 16 digits. If the command length is less than 16 digits, it fills with (00H).

Example:

Segment Play Command : Title 02, from Frame 3600 to Frame 4800  
 > 4020036000048007

BP	Data	Explanations
1216 + BARCODE_SRP #n	a4H	
+ 1	a0H	
+ 2	a2H	
+ 3	a0H	
+ 4	a0H	
+ 5	a3H	
+ 6	a6H	
+ 7	a0H	
+ 8	a0H	
+ 9	a0H	
+ 10	a0H	
+ 11	a4H	
+ 12	a8H	
+ 13	a0H	
+ 14	a0H	
+ 15	a7H	

\*BARCODE\_SRP #n : Barcode #n Search Pointer

Outline of Barcode Command : Barcode Command has these formats as follows.

DVD 4 digits command (Set the player, the video and the audio control)

DVD 6 digits command (Set the attribute control)

DVD 10 digits command (Chapter Search Command)

DVD 12-digit command (Chapter Segment Play)

DVD 14-digit command (Frame Search)

DVD 16-digit command (Segment Play)

LB compatible 4-digit command (Sets player, video and audio controls)

LB compatible 6-digit command (Chapter Search)

LB compatible 8-digit command (Chapter Segment Play)

LB compatible 10-digit command (Frame Search and Time Search)

LB compatible 14-digit command (Frame Play & Time Segment Play)

LB compatible 16-digit command (Special Effect Frame Segment Play)

The following two command functions in Barcode / Command Stack are not regulated in Barcode Format. These commands are regulated as follows.

1) End of Group mark: The first byte is (ffH), the others are (00H)

2) REPEAT: (49a3H)

\*Refer to the Barcode Format

Format of Blackboard ; Picture data:

The length of Blackboard; Picture data is 27 bytes. This is a fixed length.

Example :

Displays the picture compulsively

Title 02, from Frame 3600 to Frame 4800. And PGC number 4, PG number 2, GROUP 01, UNIT 03, Rectangle:

Coordinates are (24, 36), (260, 200); the inside of the rectangle fills with blue.

BP	Data	Explanations
1216 + BARCODE_SRP #n	46H	"F" indicates the ID of Picture
+ 1	04H	(1) Display mode; a Forced display
+ 2	02H	Starting Title Number
+ 3	00H	Starting Address Number (MSB)
+ 4	00H	Starting Address Number
+ 5	0eH	Starting Address Number
+ 6	10H	Starting Address Number (LSB)
+ 7	02H	Ending Title Number
+ 8	00H	The ending Address Number (MSB)
+ 9	00H	Ending Address Number
+ 10	12H	Ending Address Number
+ 11	c0H	Ending Address Number (LSB)
+ 12	00H	Group Number
+ 13	01H	Group Number
+ 14	00H	Unit Number
+ 15	03H	Unit Number
+ 16	00H	PGC Number
+ 17	04H	PGC Number
+ 18	02H	PG Number
+ 19	71H	(2) The kind of Picture, color
+ 20	00H	Line Width
+ 21	00H	Picture Starting Point, X (MSB)
+ 22	18H	Picture Starting Point, X (LSB)
+ 23	01H	Picture Ending Point, X (MSB)
+ 24	04H	Picture Ending Point, X (LSB)
+ 25	24H	Picture Ending Point, Y
+ 26	c8H	Picture Ending Point, Y

\*BARCODE\_SRP #n : Barcode #n Search Pointer

(1) Display mode:

- 00H : The player does nothing
- 01H : Pauses at the starting Address
- 02H : Displays "\*" while the player is in a registered Address
- 03H : Pauses and displays "\*" while the player is in a registered Address
- 04H : Forced to display the picture
- 05H : Pauses and forced to display the picture
- 0dH : Pauses at the address just before a registered Address

(2) The kind of Picture, color:

- bit7, 6, 5 : The kind of Picture
  - 0 : There is no Picture
  - 1 : Text
  - 2 : Line
  - 3 : Rectangle
  - 4 : Ellipse
  - 5 : Circle

bit4, 3, 2 : The kind of color

- 0 : White
- 1 : Black
- 2 : Gray
- 3 : Red
- 4 : Blue
- 5 : Green
- 6 : Yellow
- 7 : Orange

bit1, 0 : Paint mode

- 0 : Only frame
- 1 : The frame with filled color in inside it.
- 2 : The frame with filled color in outside it.

Format of Blackboard ; Text data in the data:

- The Blackboard length;
- Text data is a flexible length, from 25 bytes up to 344 bytes

Example :

Displays the text compulsively

Title 02, from Frame 3600 to Frame 4800; PGC number 4, PG number 2,  
GROUP 01, UNIT 03, Text in 3rd line: **Black**

BP	Data	Explanations
1216 + BARCODE_SRP #n	54H	"T" indicates the ID of Picture
+ 1	04H	(1) Display mode ; a Forced display
+ 2	02H	Starting Title Number
+ 3	00H	Starting Title Number (MSB)
+ 4	00H	Starting Address Number
+ 5	0eH	Starting Address Number
+ 6	10H	Starting Address Number (LSB)
+ 7	02H	Ending Title Number
+ 8	00H	Ending Address Number (MSB)
+ 9	00H	Ending Address Number
+ 10	12H	Ending Address Number
+ 11	c0H	Ending Address Number (LSB)
+ 12	00H	Group Number
+ 13	01H	Group Number
+ 14	00H	Unit Number
+ 15	03H	Unit Number
+ 16	00H	PGC Number
+ 17	04H	PGC Number
+ 18	02H	PG Number
+ 19	00H	Text Starting Point (MSB)
+ 20	40H	Text Starting Point (LSB)
+ 21	00H	Text Ending Point (MSB)
+ 22	44H	Text Ending Point (LSB)
+ 23	42H	Text Data :B
~	~	:lack
+ m - 1	6bH	Text Data k
+ m	ffH	0xff

\*BARCODE\_SRP #n : Barcode #n Search Pointer

\* < m < 344

Text data includes the blank spaces between words. If your text has spaces, the player memorizes whole texts with spaces from the 1st character to the last character.

(1) Display mode:

- 00H : The player does nothing
- 01H : Pauses at the starting Address
- 02H : Displays "\*" while the player is in a registered Address
- 03H : Pauses and displays "\*" while the player is in a registered Address
- 04H : Forced to display the picture
- 05H : Pauses and forced to display the picture
- 0dH : Pauses at the address just before a registered Address

PGC Number, PG Number ( In common with PICTURE data · TEXT data)

- PGC Number=0000h and PG Number=00h : One Sequential PGC
- PGC Number≠0000h and PG Number≠00h : Random/Shuffle PGC
- PGC Number≠0000h and PG Number=00h : except for above

Execution :

String	Status Return	DVD-V7300D
BU<CR>		Park mode
	R<CR>	Receives the command and
	24680100....02	starts the transfer of the data,
	6743<CR>	9320 bytes (ends with <CR>)
	R<CR>	

**5.42 Blackboard / Stack Data Download**

Function : Sends the following data to the player; Blackboard data, Barcode data, Stack data

Format : BD

Explanation : The computer sends Blackboard / Stack data to the player while it is in Park mode.

Refer to the descriptions of Blackboard / Stack Data Upload.

The Communication flows as follows.

(N=9320)

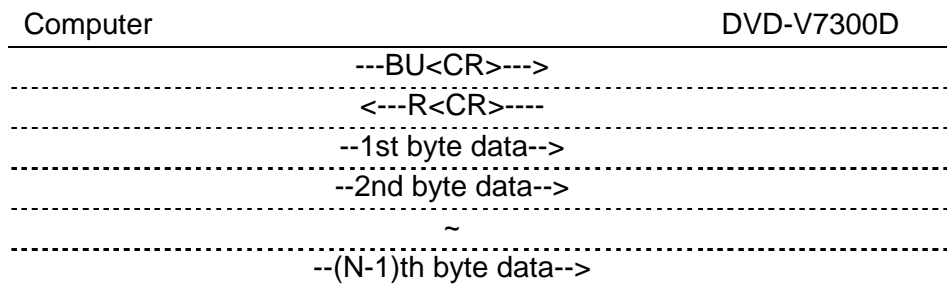

```

-----
--Nth byte data<CR>-->
-----
<---R<CR>-----

```

Execution :

String	Status Return	DVD-V7300D
BD<CR>		Park mode
24680100....0267 43<CR>	R<CR>	Receives the command and starts the receiving data, 9320 bytes. It ends with <CR>.
	R<CR>	

Data size 8420bytes = 20e4h supported by old version before 2.200 can be downloaded with this command as well.

### 5.43 Weekly Timer Data Upload

Function : Reads the data of the Weekly Timer in the player.

Format : WU

Explanation : The player sends the data to the computer after the command while it is Park mode.

The Communication flows as follows.

Flow of the communication :

```

Computer                                     DVD-V7300D
-----
---WU<CR>--->
-----
<---R<CR>-----
-----
<--1st byte data--
-----
<--2nd byte data--
-----
~
-----
<--245th byte data--
-----
<--246th byte data<CR>--
-----
<---R<CR>-----

```

Format of the data :

BP	Contents	Numbers of bytes
0 - 1	(1) Total number of the transfer data. (fixed number = 00f6H)	2 bytes
2	(2) Set the mode on Monday	1 bytes
3	(3) Set the ON hour on Monday	1 bytes

4	Set the ON minute on Monday	1 bytes
5	(4) Set the OFF hour on Monday	1 bytes
6	Set the OFF minute on Monday	1 bytes
7	(5) 00 (fixed data = 00H)	1 bytes
8	(6) Upper digit of Title number or Stack group number searched on Mon. (set with BCD)	1 bytes
9	Lower digit of Title number of Stack group number searched on Mon. (set with BCD)	1 bytes
10	(7) Upper digit of Chapter number searched on Mon. (set with BCD)	1 bytes
11	Lower digit of Chapter number searched on Mon. (set with BCD)	1 bytes
12	(2) Set the mode on Tuesday	1 bytes
• • • •	(3)~(7) • • • • • • •	• • • • • • •
22	(2) Set the mode on Wednesday	1 bytes
• • • •	(3)~(7) • • • • • • •	• • • • • • •
32	(2) Set the mode on Thursday	1 bytes
• • • •	(3)~(7) • • • • • • •	• • • • • • •
42	(2) Set the mode on Friday	1 bytes
• • • •	(3)~(7) • • • • • • •	• • • • • • •
52	(2) Set the mode on Saturday	1 bytes
• • • •	(3)~(7) • • • • • • •	• • • • • • •
62	(2) Set the mode on Sunday	1 bytes
63	(3) Set the ON hour on Sun.	1 bytes
64	Set the ON minute on Sun.	1 bytes
65	(4) Set the OFF hour on Sun.	1 bytes
66	Set the OFF minute on Sun.	1 bytes
67	(5) 00 (fixed data = 00H)	1 bytes
68	(6) Upper digit of Title number or Stack group number searched on Sun. (set with BCD)	1 bytes
69	Lower digit of Title number of Stack group number searched on Sun. (set with BCD)	1 bytes
70	(7) Upper digit of Chapter number searched on Sun. (set with BCD)	1 bytes
71	Lower digit of Chapter number searched on Sun. (set it with BCD)	1 bytes
72	(2) Set the mode on ALL day	1 bytes

Command Descriptions

73	(3) Set the ON hour on ALL day.	1 byte
74	Set the ON minute on ALL day.	1 byte
75	(4) Set the OFF hour on ALL day.	1 byte
76	Set the OFF minute on ALL day.	1 byte
77	(5) 00	1 byte
78	(6) Upper digit of Title number or Stack group number searched on ALL day. (set with BCD)	1 byte
79	Lower digit of Title number of Stack group number searched on Sun. (set with BCD)	1 byte
80	(7) Upper digit of Chapter number searched on ALL day. (set with BCD)	1 byte
81	Lower digit of Chapter number searched on ALL day. (set it with BCD)	1 byte
82	(2) Set the mode on Monday.	1 byte
83	(3) Set the ON hour on Monday.	1 byte
84	Set the ON minute on Monday.	1 byte
85	(4) Set the OFF hour on Monday.	1 byte
86	Set the OFF minute on Monday.	1 byte
87	(5) 00	1 byte
88	(6) Upper digit of Title number or Stack group number searched on Monday. (set with BCD)	1 byte
89	Lower digit of Title number of Stack group number searched on Monday. (set with BCD)	1 byte
90	(7) Upper digit of Chapter number searched on Monday. (set with BCD)	1 byte
91	Lower digit of Chapter number searched on Monday. (set it with BCD)	1 byte
92	(2) Set the mode on Tuesday	1 byte
. . . . .	(3)~(7) . . . . .	. . . . .
102	(2) Set the mode on Wednesday	1 byte
. . . . .	(3)~(7) . . . . .	. . . . .
112	(2) Set the mode on Thursday	1 byte
. . . . .	(3)~(7) . . . . .	. . . . .
122	(2) Set the mode on Friday	1 byte
. . . . .	(3)~(7) . . . . .	. . . . .
132	(2) Set the mode on Saturday	1 byte
. . . . .	(3)~(7) . . . . .	. . . . .
142	(2) Set the mode on Sunday	1 byte
143	(3) Set the ON hour on Sun.	1 byte

Command Descriptions

144	Set the ON minute on Sun.	1 byte
145	(4) Set the OFF hour on Sun.	1 byte
146	Set the OFF minute on Sun.	1 byte
147	(5) 00 (fixed data = 00H)	1 byte
148	(6) Upper digit of Title number or Stack group number searched on Sun. (set with BCD)	1 byte
149	Lower digit of Title number of Stack group number searched on Sun. (set with BCD)	1 byte
150	(7) Upper digit of Chapter number searched on Sun. (set with BCD)	1 byte
151	Lower digit of Chapter number searched on Sun. (set it with BCD)	1 byte
152	(2) Set the mode on ALL day	1 byte
153	(3) Set the ON hour on ALL day.	1 byte
154	Set the ON minute on ALL day.	1 byte
155	(4) Set the OFF hour on ALL day.	1 byte
156	Set the OFF minute on ALL day.	1 byte
157	(5) 00	1 byte
158	(6) Upper digit of Title number or Stack group number searched on ALL day. (set with BCD)	1 byte
159	Lower digit of Title number of Stack group number searched on Sun. (set with BCD)	1 byte
160	(7) Upper digit of Chapter number searched on ALL day. (set with BCD)	1 byte
161	Lower digit of Chapter number searched on ALL day. (set it with BCD)	1 byte
162	(2) Set the mode on Monday.	1 byte
163	(3) Set the ON hour on Monday.	1 byte
164	Set the ON minute on Monday.	1 byte
165	(4) Set the OFF hour on Monday.	1 byte
166	Set the OFF minute on Monday.	1 byte
167	(5) 00	1 byte
168	(6) Upper digit of Title number or Stack group number searched on Monday. (set with BCD)	1 byte
169	Lower digit of Title number of Stack group number searched on Monday. (set with BCD)	1 byte
170	(7) Upper digit of Chapter number searched on Monday. (set with BCD)	1 byte

Command Descriptions

171	Lower digit of Chapter number searched on Monday. (set it with BCD)	1 byte
172	(2) Set the mode on Tuesday	1 byte
• • • • •	(3)~(7) • • • • •	• • • • •
182	(2) Set the mode on Wednesday	1 byte
• • • • •	(3)~(7) • • • • •	• • • • •
192	(2) Set the mode on Thursday	1 byte
• • • • •	(3)~(7) • • • • •	• • • • •
202	(2) Set the mode on Friday	1 byte
• • • • •	(3)~(7) • • • • •	• • • • •
212	(2) Set the mode on Saturday	1 byte
• • • • •	(3)~(7) • • • • •	• • • • •
222	(2) Set the mode on Sunday	1 byte
223	(3) Set the ON hour on Sun.	1 byte
224	Set the ON minute on Sun.	1 byte
225	(4) Set the OFF hour on Sun.	1 byte
226	Set the OFF minute on Sun.	1 byte
227	(5) 00 (fixed data = 00H)	1 byte
228	(6) Upper digit of Title number or Stack group number searched on Sun. (set with BCD)	1 byte
229	Lower digit of Title number of Stack group number searched on Sun. (set with BCD)	1 byte
230	(7) Upper digit of Chapter number searched on Sun. (set with BCD)	1 byte
231	Lower digit of Chapter number searched on Sun. (set it with BCD)	1 byte
232	(2) Set the mode on ALL day	1 byte
233	(3) Set the ON hour on ALL day.	1 byte
234	Set the ON minute on ALL day.	1 byte
235	(4) Set the OFF hour on ALL day.	1 byte
236	Set the OFF minute on ALL day.	1 byte
237	(5) 00	1 byte
238	(6) Upper digit of Title number or Stack group number searched on ALL day. (set with BCD)	1 byte
239	Lower digit of Title number of Stack group number searched on Sun. (set with BCD)	1 byte
240	(7) Upper digit of Chapter number searched on ALL day. (set with BCD)	1 byte
241	Lower digit of Chapter number searched on ALL day. (set it with BCD)	1 byte
242 – 245	(8) Checksum	1 byte

- (1) Fixed data:  
 indicates the total data bytes of this transfer with HEX digit  
 004cH = 246byte
- (2)  
 indicates the player mode when the player turns ON  
 It specifies the player mode as follows.  
 Upper nibble  
 4: The player will seek the Title and Chapter that is written in the data  
 8: The player will execute the Stack that is specified in the data
- Lower nibble (indicates the day)  
 0: Monday  
 1: Tuesday  
 2: Wednesday  
 3: Thursday  
 4: Friday  
 5: Saturday  
 6: Sunday  
 7: ALL
- (3)  
 indicates the hour that the player's power will turn ON  
 The hour is used with the minute and is expressed as 00 through 23. The ffH means that the hour is not written.
- (4)  
 indicates the minute that the player's power will turn ON  
 The minute is used with the hour and is expressed as 00 through 59. The ffH means that the minute is not written.
- (5) Fixed data:  
 00H
- (6)  
 indicates the upper and lower digit of Title number or Stack group number according to the player mode in which it is written (refer to (2))  
 When the upper nibble of the mode is 4, it indicates a Title number. When the mode is 8, it indicates a Stack group number (shown with BCD).

(7)

indicates the upper and lower digit of Chapter number or Stack group number according to the player mode in which it is written (refer to (2))

When the upper nibble of the mode is 4, it indicates a Chapter number. When the mode is 8, it fixes 00H as upper and 01H as lower (shown with BCD).

(8)

checksum of the data that indicates the result of adding from BP 0 to BP 242 (shown with HEX (double word))

Example :

Monday, Turning ON at 8:30 (AM) and turning OFF at 17:20 (5:20 PM) / seek Title 20, Chapter 5

Tuesday, Turning ON at 9:30 only. Execute Stack group 123.

BP	Data	Explanations
0	00H	
1	4cH	
2	40H	The mode of Monday
3	08H	8 o'clock (Hour of turning on )
4	30H	30 minutes (Minute of turning on)
5	17H	17 o'clock (Hour of turning off)
6	20H	20 ninutes (Minute of turning on)
7	00H	Fixed data
8	00H	The upper digit of Title number
9	20H	The lower digit of Title number
10	00H	The upper digit of Chapter number
11	05H	The lower digit of Chapter number
12	81H	The mode of Tuesday
13	09H	9 o'clock
14	30H	30 minutes
15	ffH	
16	ffH	
17	00H	Fixed data
18	01H	The upper digit of Stack group
19	23H	The lower digit of Stack group
20	00H	Fixed data
21	01H	Fixed data
22		~
~		~

Execution :

String	Status Return	DVD-V7300D
WU<CR>		Park mode
	R<CR> 004c4008....00 1ab6<CR>	Receives the command and starts the transfer of the data, 246 bytes. It ends with <CR>.
	R<CR>	

#### 5.44 Weekly Timer Data Download

Function : Sends the Weekly Timer data to the player

Format : WD

Explanation : The computer writes the Weekly Timer data to the player while it is in Park mode.

Refer to the descriptions of Weekly Timer Data Upload.

The Communication flows as follows.

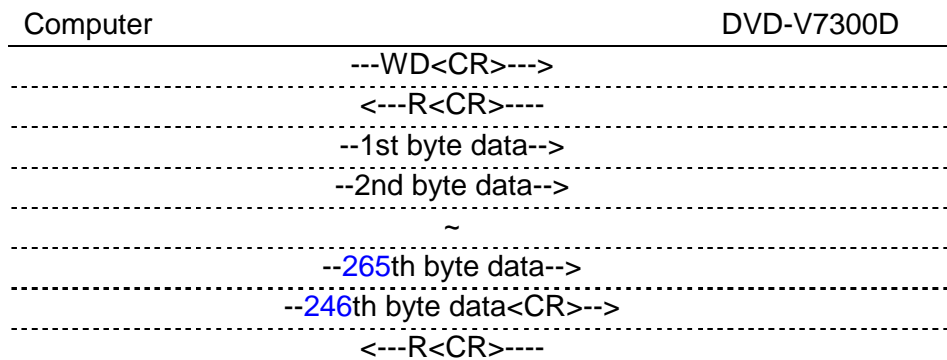

Execution :

String	Status Return	DVD-V7300D
WD<CR>		Park mode
004c4008....001a b6<CR>	R<CR>	Receives the command and starts the transfer of the data, (246 bytes) then ends with <CR>
	R<CR>	

#### 5.45 Text File Data Upload

Function : Reads the Text File data from the player

Format : UU

Explanation : The computer writes the Weekly Timer data to the player while it is in Park mode. It ends with <EOF(End Of File: 1aH)>.

If the player fails to display the Text File, it returns an Error code.

Execution :

String	Status Return	DVD-V7300D
UU<CR>	R<CR> PIONEER ANNOUNCED NEW INDUSTRIAL DVD- VIDEO PLAYER On February 2, 1999, Pioneer New Media Technologies, Inc. unveiled its ..... or registered trademarks of their respective owners <EOF>	While Text File is being displayed Receives the command and starts the transfer of all the Text File data from the player. It ends with <EOF>
	R<CR>	

## 6. CURRENT PLAYER CONDITION REQUEST DESCRIPTIONS

### 6.1 P-Block Number Request

Function : The command returns information for the following groups:

DVD – Title Numbers, Chapter Numbers, Time

LB Compatible DVD (CAV) – Title Chapter, CAV Frame Numbers

LB Compatible DVD (CLV) – Title, Chapter, CLV Time

CD/VCD – Track Numbers, Index Numbers, Block Numbers, Time

Format : ?A

Explanation : If the P-Block Number Request command is sent to a DVD disc, Title numbers, Chapter numbers and Time Code information are grouped together then the data is returned in a single report. When the command is sent to a LB-compatible DVD disc, the player returns Title numbers, Chapter numbers and CAV Frame numbers or CLV Time Codes. A request sent to a CD/VCD disc returns track numbers, index numbers, block numbers and time codes.

The continuous frame count information may be missing from a report if the P-Block Number Request is sent while the player is in normal playback mode. The player does not update frame counts while processing this command. Rather than returning an incorrect frame count, the player ignores the request.

If the player is in Random Access Mode or is reading the lead-in/lead out area of the disc, the report contains correct values.

Execution :

String	Status Return	DVD-V7300D
?A<CR>	1201033545<CR>	Play mode (CD) <i>track 12, index 1, 3 minutes, 35 seconds 45 blocks</i>
?A<CR>	0135001247<CR>	Play mode (DVD) <i>title 1, chapter 35, 12 minutes, 47 seconds</i>
?A<CR>	0401002552<CR>	<i>title 4, chapter 1, frame 2552</i>

### 6.2 Title/Track Number Request

Function : Returns the current title/track number

DVD : Title

CD/VCD : Track

Format : ?R

Explanation : The player returns the contents of the Title/Track Number Register. The track number is a 2-digit integer. Correct values show only when the player is in Random Access Mode or is playing the lead-in/out area of the disc.

Execution :

String	Status Return	DVD-V7300D
?R<CR>	12<CR>	Play mode (CD) <i>Player plays Track 12</i>

### 6.3 Chapter Number Request (DVD)

Function : Returns the current chapter number

Format : ?C

Explanation : The player returns the contents of the Chapter Number Register. The chapter number is a 2-digit integer. If a disc does not have chapter numbers, the player returns an error message (E04). Correct values show only when the player is in Random Access Mode or is playing the lead-in/out area of the disc.

Execution :

String	Status Return	DVD-V7300D
?C<CR>	12<CR>	Play mode (CD) <i>Player plays Chapter 12</i>

### 6.4 Time Code Request

Function : Returns the current Time Code

Format : ?T

Explanation : The player returns the contents of the Current Time/Frame Register.

If a DVD disc is playing, a 3-digit number is assigned for minutes and a 2-digit number is assigned for seconds.

If a CD or VCD disc is playing, a 1-digit number is assigned for hours (fixed 0), a 2-digit number is assigned for minutes and a 2-digit number is assigned for seconds.

If the player is in Random Access mode or if the player is reading the lead-in/lead-out area of the disc, the returned value is current and correct.

If a disc lacks time information, the player returns error message E04.

If a disc time code fails to be read correctly, the player retains the previous time code.

Execution :

String	Status Return	DVD-V7300D
		Play mode (VCD)
?T<CR>	03213<CR>	<i>32 minutes, 13 seconds</i>
?T<CR>	11742<CR>	<i>117 minutes, 42 seconds</i>

## 6.5 Index Number Request (CD, VCD)

Function : Returns the current Index number

Format : ?I

Explanation : The player returns the current index number as a 4-digit integer. Correct values show only when the player is in Random Access Mode or is reading the lead-in/lead-out area of the disc.

Execution :

String	Status Return	DVD-V7300D
?I<CR>	0102<CR>	Play mode <i>track 1, index 2</i>

## 6.6 Frame Number Request (DVD)

Function : Returns the current frame number

Format : ?F

Explanation : The player returns the contents of the Current Frame Register.

The player may experience a conflict between the command receiving/handling and the frame number updating. Thus, continuous frame numbers may be unavailable when the system is in Playback mode.

If the command is sent to a disc without frame numbers, the player returns error message E04.

Accurate, current values are available when the player is in Random Access mode or is reading the lead-in/lead-out area of the disc.

If a disc frame number cannot be read correctly, the player retains the previous value.

Execution :

String	Status Return	DVD-V7300D
?F<CR>	0002047<CR>	Play mode <i>frame 2047</i>
?F<CR>	0095010<CR>	Play mode <i>frame 950107</i>

### 6.7 Block Number Request (CD, VCD)

Function : Returns the current block number

Format : ?B

Explanation : The player returns the value of the current block number as a 7-digit integer. Current values show only when the player is in Random Access mode or is reading the lead-in/lead-out area of the disc.

If a block number cannot be read correctly, the player retains the previous value.

Execution :

String	Status Return	DVD-V7300D
?B<CR>	0115310<CR>	Play mode <i>11 min, 53 sec, 10 blocks</i>

### 6.8 Total Frame Request (DVD)

Function : Returns the current total frame number of the title

Format : ?Y

Explanation : The player returns the current total frame number of the title.

Execution :

String	Status Return	DVD-V7300D
?Y<CR>	0124832<CR>	Play mode <i>frame 124832</i>

### 6.9 TOC Information Request (CD/VCD)

Function : Returns the Table of Contents (TOC) information

Format : ?Q

Explanation : The player returns the track number of the first track, the track number of the last track and the absolute time of starting lead-out.

Status information is returned in the following format:

C<sub>1</sub>C<sub>2</sub>C<sub>3</sub>C<sub>4</sub>C<sub>5</sub>C<sub>6</sub>C<sub>7</sub>C<sub>8</sub>C<sub>9</sub>C<sub>10</sub><CR>

C <sub>1</sub> C <sub>2</sub>	first track number
C <sub>3</sub> C <sub>4</sub>	last track number
C <sub>5</sub> C <sub>6</sub> C <sub>7</sub> C <sub>8</sub> C <sub>9</sub> C <sub>10</sub>	absolute time of starting lead-out

Execution :

String	Status Return	DVD-V7300D
?Q<CR>	0109665544<CR>	Play mode <i>first track is 1, last track is 9, lead-out time is 66 min, 55 sec, 44 blocks</i>

## 6.10 Disc Region Code Request(DVD)

Function : Returns the region code of the disc

Format : ?G

Explanation : The player returns the approved region code(s) designated on the disc. Each bit indicates a region in a returned byte from the player. Bit 0 (LSB) indicates region 1, bit 1 indicates region 2, ..., bit 5 indicates region 6. Value 0 shows the disc as playable in its region.

Execution :

String	Status Return	DVD-V7300D
?G<CR>	F9<CR> (=11111001B)	Play mode <i>Region code 2 and 3</i>
?G<CR>	C0<CR> (=11000000B)	Play mode <i>Region code 1, 2, 3, 4, 5 and 6 (ALL)</i>

## 6.11 DVD Disc Status Request(DVD)

Function : Returns the attributes of the DVD disc being played

Format : ?V

Explanation : The player returns the attributes of a DVD disc. Discs other than DVD, cause the player to return an error message (E04).

Status information is returned in the following format:

C<sub>1</sub>C<sub>2</sub>C<sub>3</sub>C<sub>4</sub>C<sub>5</sub><CR>

C <sub>1</sub>	Disc Mount	0 = No	1 = Yes	X = Unknown
C <sub>2</sub>	Layer Structure	0 = Single	1 = Dual	X = Unknown
C <sub>3</sub>	Path Type	0 = Parallel	1 = Opposite	X = Unknown
C <sub>4</sub>	Chapter Search	0 = Disable	1 = Available	X = Unknown
C <sub>5</sub>	Time Search	0 = Disable	1 = Available	X = Unknown

Execution :

String	Status Return	DVD-V7300D
?V<CR>	0XXXX<CR>	<i>Disc is not mounted</i>
?V<CR>	10010<CR>	<i>available Chapter search but disable Time search</i>
?V<CR>	E04<CR>	<i>Error – except DVD disc loaded</i>

### 6.12 LD Disc Status Request (LB-compatible DVD)

Function : Returns the attributes of the LD disc being played

Format : ?D

Explanation : The player returns the attributes of the LD disc. If the disc is other than LD or LB-compatible DVD, the player returns an error message (E04).

Status information is returned in the following format:

C<sub>1</sub>C<sub>2</sub>C<sub>3</sub>C<sub>4</sub>C<sub>5</sub><CR>

C <sub>1</sub>	Disc Mount	0 = No	1 = Yes	X = Unknown
C <sub>2</sub>	CAV/CVL	0 = CAV	1 = CLV	X = Unknown
C <sub>3</sub>	Disc Size	0 (fixed)		X = Unknown
C <sub>4</sub>	Disc Side	0 (fixed)		X = Unknown
C <sub>5</sub>	Chapter Code	0 = No	1 = Yes	X = Unknown

Execution :

String	Status Return	DVD-V7300D
?D<CR>	0XXXX<CR>	<i>Disc is not mounted</i>
?D<CR>	11001<CR>	<i>CLV disc with chapter code</i>
?D<CR>	E04<CR>	<i>Error - CD or VCD disc loaded</i>

### 6.13 CD Disc Status Request(CD)

Function : Returns the attributes of the CD disc being played

Format : ?K

Explanation The player returns the attributes of the CD disc. If the disc is other than CD, the player returns an error message (E04).

Status information is returned in the following format:

C<sub>1</sub>C<sub>2</sub>C<sub>3</sub>C<sub>4</sub>C<sub>5</sub>C<sub>6</sub>C<sub>7</sub>C<sub>8</sub><CR>

C <sub>1</sub>	Disc Mount	0 = No	1 = Yes	X = Unknown
C <sub>2</sub>	Not Used	X (fixed)		
C <sub>3</sub>	Not Used	X (fixed)		
C <sub>4</sub>	Not Used	X (fixed)		
C <sub>5</sub>	Not Used	X (fixed)		
C <sub>6</sub>	VCD	0 = No	1 = Yes	X = Unknown
C <sub>7</sub>	Reserved	X (fixed)		
C <sub>8</sub>	Reserved	X (fixed)		

Execution :

String	Status Return	DVD-V7300D
?K<CR>	0XXXXXXX<CR>	<i>Disc is not mounted</i>
?K<CR>	1XX1XXXX<CR>	<i>CDV</i>
?K<CR>	E04<CR>	<i>DVD</i>

### 6.14 Register A Set

Function : The current setting of Register A is rewritten

Format : Integer RA

Explanation : The command rewrites detailed display attributes into Register

A. The player offers three settings:

- Frame Number/Time code
- Title, Chapter Number/Track Number
- User's Area

Note: When playing back a DVD disc and selecting Frame Number/Time code, the Frame Number is usually displayed on the screen. [During playback of movies, there may be a difference between the frame number display and the actual frame number.](#) But when playing back a DVD disc then selecting both Frame Number/Time code and Time code(DVD), Time code is displayed. Playing back a CD or VCD disc, Time Code and Time Code are displayed.

The available display combinations are listed in the following table (Default value is 3):

Arg	Function	User's	T&CH / Track	Frame / Time	Time (DVD)
0	Display OFF	0	0	0	0
1	Frame Number (DVD)/Time Code (CD)	0	0	1	0
2	Title & Chapter Number/Track Number	0	1	0	0
3 (default)	Frame Number (DVD) / Time Code (CD, VCD) + Title, Chapter, Frame/Track, Time	0	1	1	0
4	User's area	1	0	0	0
5	User's area + Argument 1	1	0	1	0
6	User's area + Argument 2	1	1	0	0
7	User's area + Argument 3	1	1	1	0
11	Time Code (DVD, CD, VCD)	0	0	1	1
13	Time Code (DVD, CD, VCD) + Title & Chapter Number/Track Number + User's Area	0	1	1	1
15	Time Code (DVD, CD, VCD) + User's Area	1	0	1	1
17	Time Code (DVD, CD, VCD) + Title & Chapter Number/Track Number + User's Area	1	1	1	1

The Display Control command turns ON and OFF the character displays. And this Register A Set command specifies what is displayed on the screen.

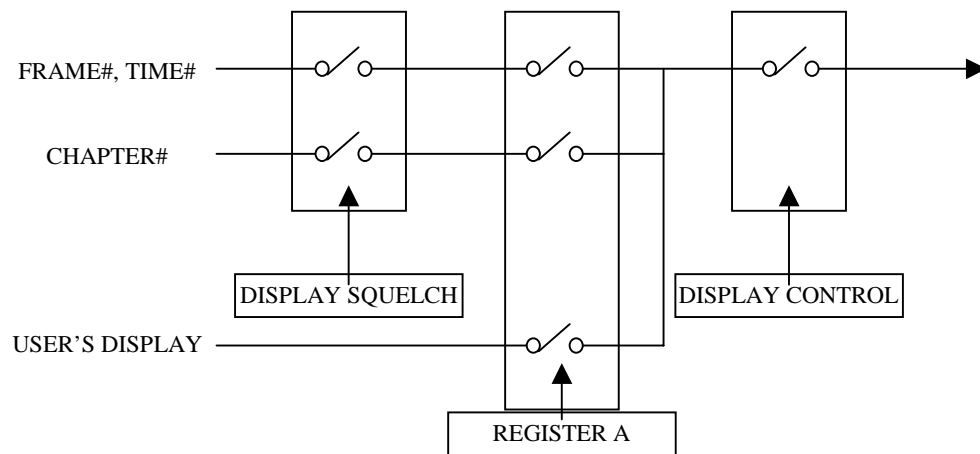

The screen display positions are pictured below.

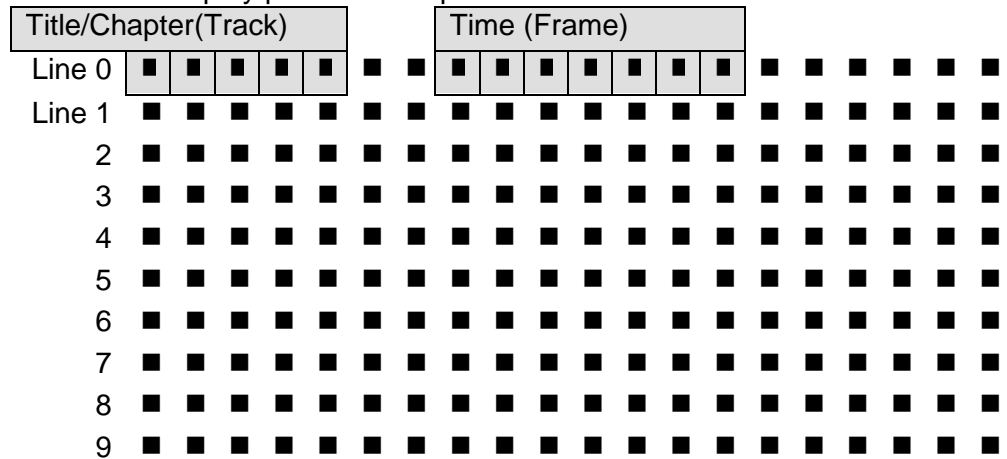

Line 0 displays the Time Code/Frame Number and/or Title/Chapter/Track Number.

The user's area has lines numbered from 0 to 9 with a total of 10 lines available. If line 0 is designated to show system information, all following lines are not displayed.

The player allows/displays up to 320 characters (32 characters per line with 10 lines available). Follow the instructions below to create a User's Display:

1. Select User's Display in Register A
2. Set the display data using a print character command
3. Turn display switch ON

Execution :

String	Status Return	DVD-V7300D
1DS<CR>	R<CR>	Display Off to Display On
1RA<CR>	R<CR>	<i>Only frame number is displayed</i>

## 6.15 Register B Set

Function : The current setting of Register B is rewritten

Format : Integer RB

Explanation : The command rewrites Audio and Video Squelch Switch attributes into Register B. The squelch switch is controlled automatically in accordance with the player's operating mode. However, by rewriting the contents of Register B, it is possible to invalidate the squelch switch.

Argument	Function
0 (default)	Normal
64	Audio SQ invalid
128	Video SQ invalid
192	VD/AD SQ invalid

## 6.16 Register D Set

Function : The current setting of Register D is rewritten

Format : Integer RD

Explanation : Register D contains the termination setting of the serial communication (RS232). There are two choice: "CR", "CR + LF". The default of the Register D is 0.

Argument	Function
0 (default)	CR
64	CR + LF

## 6.17 Print Character

Function : Characters are written into the User's Display Area  
(Not to be issued simultaneously with other commands)

Format : Integer PR <CR>

Character string <CR>

Explanation : The command writes a character string for one line into the User Display Area (turn on the User Display Specification in Register A).

Follow the instructions listed below to create printed characters.

1. Specify the line number using an integer in the range 0 ~ 9
2. Enter the command character PR
3. Enter the terminate code <CR>
4. Specify the character string to enter in the next command string  
(*enter a character string up to 32 characters in length*)

Available characters are shown in the table below (from 20h through 9Fh):

	0	1	2	3	4	5	6	7	8	9	A	B	C	D	E	F
2		!	"	#	\$	%	&	'	(	)	*	+	,	-	.	/
3	0	1	2	3	4	5	6	7	8	9	:	;	<	=	>	?
4	@	A	B	C	D	E	F	G	H	I	J	K	L	M	N	O
5	P	Q	R	S	T	U	V	W	X	Y	Z	[	¥	]	^	_
6	'	a	b	c	d	e	f	g	h	i	j	k	L	m	n	o
7	p	q	r	s	t	u	v	w	x	y	z	{		}	~	*1
C	À	Á	Â	Ã	Ä	Å	Æ	Ç	È	É	Ê	Ë	Ì	Í	Î	Ï
D	Ð	Ñ	Ò	Ó	Ô	Õ	Ö	×	Ø	Ù	Ú	Û	Ü	Ý	Þ	ß
E	à	á	â	ã	ä	å	æ	ç	è	é	ê	ë	ì	í	î	ï
F	ð	ñ	ò	ó	ô	õ	ö	÷	ø	ù	ú	û	ü	ý	þ	ÿ

\*1 can not be used

Execution :

String	Status Return	DVD-V7300D
4RA1DS<CR>	R<CR>	<i>Register A and Display control set</i>
4PR<CR>	R<CR>	<i>Select Line 4</i>
*** DVD-V7300D ***<CR>	R<CR>	<i>Displays the characters like this ***DVD-V7300D***</i>

## 6.18 Clear Screen

Function : Clears the characters shown in the User Display Area

Format : CS

Explanation : The player clears all characters from the User Display area. To clear only a particular line, use the PR command to overwrite the line with spaces.

Execution :

String	Status Return	DVD-V7300D
CS<CR>	R<CR>	<i>All lines are cleared</i>
3PR<CR>	R<CR>	<i>Select line 3</i>
HELLO!<CR>	R<CR>	<i>Write letters on line 3, HELLO!</i>
3PR<CR>	R<CR>	<i>Select line 3</i>
<CR>	R<CR>	<i>Clear only line 3</i>

### 6.19 Real Time Clock Set

Function : Sets the real time clock

(Not to be issued simultaneously with other commands)

Format : WW <CR>

7 Bytes integer <CR> (=YYMMDDWWHHMMSS<CR>)

Explanation : The real time clock may be set using the following format:

YY	the last two digits of year
MM	month
DD	date
WW	day, 00 means Monday, 06 means Sunday
HH	hour 24-hour format
MM	minute
SS	second

NOTE: Input the 7-bytes integer as a single entry. If an integer is less than 7-bytes in length, the player returns an error message.

Execution :

String	Status Return	DVD-V7300D
WW<CR>	R<CR>	<i>Set Real Time Clock setting mode</i>
----- 00040102083025<CR>	R<CR>	<i>Sets Wednesday, April First, 8:30:25 AM, 2000</i>

### 6.20 Advanced Feature Menu Set

Function : The current setting of [ADV.SETUP](#) Menu is rewritten

Format : Integer MS

Explanation : The command rewrites the [ADV.SETUP](#) Menu settings. Basically, the setting is expressed with an integer value. The value is made up of the sum of each selected argument. The factory default is set to 0. The player returns an error code if the command is issued while the [ADV.SETUP](#) Menu is on the screen.

The Advanced Feature Menu Request command (?S) reveals the current setting.

Current Address Request Descriptions

ARG.	FUNCTION	Description	
		0	1
1	WEEKLY TIMER	OFF	ON
2	POWER ON START	OFF	ON
4	TITLE PLAY MODE	SINGLE	ALL
8	REPEAT MODE	( 0 ) OFF ( 8 ) CHAPTER ( 1 6 ) TITLE ( 2 4 ) D I S C ( TitlePlayMode=1 時 )	
1 6			
3 2	BAUD RATE	4 8 0 0 b p s	9 6 0 0 b p s
6 4	TRAY LOCK	OFF	ON
1 2 8	BLACKBOARD LOCK	OFF	ON
2 5 6	STACK MODE OSD	ON	OFF
5 1 2	REV STEP/REV PLAY	VOBU	Frame
1 0 2 4	PLAYER CONTRL PANEL Selectable	( 0 ) Selectable ( 1 0 2 4 ) Always off ( 2 0 4 8 ) Always on	
2 0 4 8			
4 0 9 6	SETUP LOCK	ON	OFF
8 1 9 2	EXTERNAL OPTION SW	Standard	Limit
1 6 3 8 4	EXTERNAL SYNC	( 0 ) OFF ( 1 6 3 8 4 ) NTSC ( 3 2 7 6 8 ) PAL	
3 2 7 6 8			
6 5 5 3 6	AV SYNC COMPENSATE	ON	OFF

\*1): (TitlePlayMode +1)

\*2): This function is available on Japan model only.

The setting value is calculated as follows.

$$\begin{aligned}
 \text{The value} = & \frac{1 * (0/1) + 2 * (0/1) + 4 * (0/1) + (0/8/16/24)}{\text{WeeklyTimer PowerOnStart TitlePlayMode RepeatMode}} \\
 & + \frac{3 2 * (0/1) + 6 4 * (0/1) + 1 2 8 * (0/1) + 2 5 6 * (0/1)}{\text{BaudRate TrayLock BlackboardLock Stack Mode OSD}} \\
 & + \frac{5 1 2 * (0/1) + 8 1 9 2 * (0/1) + 1 6 3 8 4 * (0/1 \sim 2)}{\text{EV STEP/REV PLAY EXTERNAL OPTION SW EXTERNAL SYNC}} \\
 & + \frac{6 5 5 3 6 * (0/1)}{\text{AV SYNC COMPENSATE}}
 \end{aligned}$$

Execution :

String	Status Return	DVD-V7300D
112MS<CR>	R<CR> (return rate is 9600bps)	<i>Title repeat mode (16)</i> <i>Baud rate is 9600bps (32)</i> <i>Tray lock on (64)</i>

## 6.21 Communication Control Set

Function : Selects the communication mode

Format : Integer CM

Explanation : The command rewrites the contents of the Communication Control Register (CCR).

The CCR default value is set to Mode 3 (ON); however, the CCR Automatic Status may be switched OFF. Use the command to toggle to the required mode.

Argument	Mode	Auto Status
2	Mode-2	OFF
3	Mode-3	ON

Execution :

String	Status Return	DVD-V7300D
2CM<CR>	R<CR>	<i>CCR = 3 (Default Communication Mode)</i> <i>to CCR = 2 (Communication Mode-2)</i>

## 6.22 Player Active Mode Request

Function : Returns the current activity mode of the player

Format : ?P

Explanation : The command confirms whether or not the player is running in the Random Access mode. The player returns an Active mode classification from the table below.

P00	Open
P01	Park
P02	Setup
P03	Unload
P04	Play

P05	Still
P06	Pause
P07	Search
P08	Scan
P09	Multi-speed

The following table provides fuller explanations for each Active mode:

P00 (Open)	Disc tray is open
P01 (Park)	Disc rotation is stopped
P02 (Setup)	Preparation is being made for playback
P03 (Unload)	Disc rotation stops and disc tray opens
P04 (Play)	Audio and video are played at normal speed
P05 (Still)	Playback stops with video held on screen
P06 (Pause)	Playback stops and video is erased from screen
P07 (Search)	A specified address is searched for, a multi-track jump is in progress, or a search for user's code is in progress
P08 (Scan)	Fast forward is in progress
P09 (Multi-speed)	Playback occurs at any one of several speeds

Execution :

String	Status Return	DVD-V7300D
?P<CR>	P04<CR>	Play mode
ST<CR>	R<CR>	Still mode
?P<CR>	P05<CR>	Play mode

### 6.23 Player Model Name Request

Function : Returns player model name

Format : ?X

✘Explanation : The command returns the player's name as P1558XX where P1558 is the series name and XX is a 2-digit serial code (not the product serial number). The player ID:XX is 01 for firmware Version1.016, :02 for Version1.036

Execution :

String	Status Return	DVD-V7300D
?X<CR>	P155801<CR>	Series name P1558 and code 01

### 6.24 Real Time Clock Request

Function : Returns the Real Time Clock

Format : ?W

Explanation : The command returns the Real clock time.

YY	the last two digits of year
MM	month
DD	date
WW	day, 00 means Monday, 06 means Sunday
HH	hour 24-hour format
MM	minute
SS	second

Execution :

String	Status Return	DVD-V7300D
?W<CR>	00061002142520<CR>	<i>Wednesday, June 10th, 14:25:20 AM, (20)00</i>

## 6.25 Advanced Feature Menu Request

Function : Returns the current setting of [ADV.SETUP](#) Menu.

Format : ?S

Explanation : The player returns the current setting of the [ADV.SETUP](#) Menu. The return is expressed as an integer value. The value is made up of the sum of the selected arguments. The factory default is set to 0. The player returns an error code if the command is issued when the player is showing [ADV.SETUP](#) Menu on the screen. See the description of Advanced Feature Menu Set (MS).

Execution :

String	Status Return	DVD-V7300D
?S<CR>	112<CR>	<i>Title repeat mode (16) Baud rate is 9600bps (32) Tray lock on (64)</i>

## 6.26 Player Region Code Request

Function : Returns player region code

Format : ?H

Explanation : The command returns the player's region code(s).

Execution :

String	Status Return	DVD-V73D00
?H<CR>	02<CR>	<i>Region Code 2</i>

**6.27 CCR Mode Request**

Function : Returns the current communication mode

Format : ?M

Explanation : The command returns the contents of the Communication Control Register (CCR).

The CCR default value is set to Mode 3 (ON).

CM2	Mode-2
CM3	Mode-3

Execution :

String	Status Return	DVD-V7300D
?M<CR>	CM3<CR>	CCR = 3 ( <i>Default Communication Mode</i> )

**6.28 Input Number Request**

Function : Returns input numbers

Format : ?N

Explanation : The player waits to send numbers through to any peripherals. If numbers are input, the player returns the input numbers.

Execution :

String	Status Return	DVD-V7300D
?N<CR>		<i>Waits to input the numeric numbers</i>
7<CR>	7<CR>	<i>7 entered from keyboard</i>

**6.29 Error Code Request**

Function : Returns the latest error code

Format : ?E

Explanation : The player returns the most recent error codes. The report consists of Error Codes logged since the unit was turned on.

**6.30 Input Unit Request**

Function : Returns a code for data input through a Remote control

Format : # I

Explanation : The player returns a four-digit ASCII-Hex code that represents commands sent from a remote control.

There are two code types, one is a four-digit code, the other is a eight-digit code (Extension code). When the input command data is two words (eight-digit) in length, the player truncates or shortens the information. A truncated code consists of an Upper Byte from the first code and a Lower Byte from the second code. The player creates a Returning Code or Double Code from these two bytes.

Once the player returns an Input Code, a FFFFh Code (no reactions from the remote control) repeats until a new code is sent from the remote control.

Execution :

String	Status Return	DVD-V7300D
		<i>Receives the Pause Key command -A39F</i>
#I<CR>	A39F<CR>	
#I<CR>	FFFFh<CR>	
		<i>Receives the Pause Key command - A399_A3BE</i>
#I<CR>	A3BE<CR>	
#I<CR>	FFFFh<CR>	

### 6.31 Input Barcode Data Request

Function : Returns input data through a Barcode Reader

Format : #B

Explanation : The player returns an ASCII code that represents commands sent from a barcode reader.

NOTE: When the input data is unacceptable for the current disc type, the player returns an invalid code.

Execution :

String	Status Return	DVD-V7300D
#B<CR>	4307<CR>	<i>Receives a Play code about DVD disc</i>

### 6.32 Register A Request

Function : Returns the contents of Register A

Format : \$A

Explanation : The player returns a detailed list of the Register A attributes.

Status information is returned in the following format:

AC<sub>8</sub>C<sub>7</sub>C<sub>6</sub>C<sub>5</sub>C<sub>4</sub>C<sub>3</sub>C<sub>2</sub>C<sub>1</sub><CR>

C <sub>8</sub> , C <sub>7</sub> , C <sub>6</sub>	(Fixed 0)		
C <sub>5</sub>		0 = Off	1 = On
C <sub>4</sub>	(Fixed 0)		
C <sub>3</sub>	Displays User's Area	0 = Off	1 = On
C <sub>2</sub>	Displays Title & Chapter Numbers	0 = Off	1 = On
C <sub>1</sub>	Displays Frame Number (DVD) or Time Code (CD, VCD)	0 = Off	1 = On

Execution :

String	Status Return	DVD-V7300D
3RA<CR>	R<CR>	<i>Sets to Register A</i>
\$A<CR>	A00000011<CR>	<i>Requests information from Register A</i>

### 6.33 Register B Request

Function : Returns the contents of Register B

Format : \$B

Explanation : The player returns the Audio and Video squelch attributes from Register B.

Status information is returned in the following format:

BC<sub>8</sub>C<sub>7</sub>C<sub>6</sub>C<sub>5</sub>C<sub>4</sub>C<sub>3</sub>C<sub>2</sub>C<sub>1</sub><CR>

C <sub>8</sub>	Video Squelch	0 = Permission Granted	1 = Forbidden
C <sub>7</sub>	Audio Squelch	0 = Permission Granted	1 = Forbidden
C <sub>6</sub> to C <sub>1</sub>	(Fixed 0)		

Execution :

String	Status Return	DVD-V7300D
128RB<CR>	R<CR>	<i>Sets the Register B</i>
\$B<CR>	B10000000<CR>	<i>Requests information from Register B</i>

### 6.34 Register D Request

Function : Returns the contents of Register D

Format : \$D

Explanation : The player returns the TxD termination setting from Register D.

Status information is returned in the following format:

DC<sub>8</sub>C<sub>7</sub>C<sub>6</sub>C<sub>5</sub>C<sub>4</sub>C<sub>3</sub>C<sub>2</sub>C<sub>1</sub><CR>

C <sub>8</sub>	Fixed 0		
C <sub>7</sub>	TxD termination	0 = CR	1 = CR + LF
C <sub>6</sub>	Fixed 0		
C <sub>5</sub>	Fixed 0		
C <sub>4</sub>	Fixed 0		
C <sub>3</sub>	Fixed 0		
C <sub>2</sub>	Fixed 0		
C <sub>1</sub>	Fixed 0		

Execution :

String	Status Return	DVD-V7300D
64RB<CR>	R<CR>	<i>Sets the Register D</i>
\$D<CR>	D0100000<CR>	<i>Requests information from Register B</i>

### 6.35 Menu Call (DVD)

Function : Calls disc menu or goes back to the former address

Format : Integer MC

Explanation : If the disc has the disc menu in its contents, the root menu or the title menu comes up on the screen. If the screen is stilled or is playing, these menus come up on the display. The command specifies the menu type with two integer numbers.

<u>Integer</u>	<u>Menu type</u>
1	Title
2	Root

If the player receives the command without any integer while playing a menu, the player go back to the address that it played or stilled before.

If the command is valid for the situation, the player immediately returns "R<CR>".

If the disc is missing the requested menu, [1 or 2 MC<CR>], the player returns an error message (E04).

\*: If the command is available, "R<CR>" appears immediately on the screen. However, the command is held or incompletely executed.

Execution :

String	Status Return	DVD-V7300D
		Plays some video title
2MC<CR>	R<CR>	Shows the root menu
MC<CR>	E11<CR>	Reverses back to the previous title

### 6.36 Numeric Button (DVD)

Function : Selects the button and executes by number

Format : Integer NB

Explanation : The command selects the menu button highlighted on the screen and executes the action assigned to the button. The command emulates the "digit" key on the remote control while the button resides on the display.

If the command is valid for the current player activity, the player immediately returns "R<CR>".

If the disc that is being played does not have the button in that screen when the command is issued, an error message (E06) is returned.

\* If the command is available, "R<CR>" displays on the screen immediately. However, this does not confirm that the command is executed completely.

Execution :

String	Status Return	DVD-V7300D
		Shows the disc menu
3BT<CR>	R<CR>	Selects and executes the button #3

### 6.37 Button Select (DVD)

Function : Selects the button (arrow key emulation)

Format : Integer CU

Explanation : The command selects the menu button displayed on the screen. The command emulates the "arrow" key on the remote control while the button exists on the screen. The command specifies the direction with four integer numbers.

<u>Integer</u>	<u>directions</u>
1	Up
2	Down
3	Left
4	Right

If the command is valid for the situation, the player immediately returns "R<CR>".

If there are no buttons on the screen when the command is issued, an error message (E04) is returned.

\*: If the command is available, "R<CR>" appears on the screen immediately. However, this does not confirm that the command is executed completely.

Execution :

<u>String</u>	<u>Status Return</u>	<u>DVD-V7300D</u>
		Shows the disc menu
2CU<CR>	R<CR>	Moves the cursor down to the next button

### 6.38 Enter Button (DVD)

Function : Fixes the button and executes

Format : Integer ET

Explanation : The command fixes the button on the screen after the execution of the command "CU" with an integer. The player executes the program that is assigned to that button. The command emulates the "enter" key on the remote control while the button resides on the screen.

If the command is able to use in that player situation, the player returns immediately "R<CR>".

If there are no buttons on the screen when the command is issued, an error message (E04) is returned.

\*: If the command is available, "R<CR>" appears on the screen immediately. However, this does not confirm that the command is executed completely.

Execution :

String	Status Return	DVD-V7300D
		Shows the disc menu
2CU<CR>	R<CR>	Moves to the below button from the prior one
ET<CR>	R<CR>	Fixes the selection and executes the program that is assigned on it

Function : Emulates the “right” click of the mouse

Format : argument1, argument2 ET

Explanation : The command emulates the “right” click of the mouse while the cursor is on the screen. The command specifies the position of the cursor with two arguments. The format is stated below.

Argument1	Argument 2	Position
000000		Upper left limitation on the screen
	719479	Lower right limitation on the screen
X <sub>1</sub> X <sub>2</sub> X <sub>3</sub> Y <sub>1</sub> Y <sub>2</sub> Y <sub>3</sub>		Anywhere on the screen

If the arguments are available, the player returns immediately “R<CR>”\*.

If the argument number is unavailable, an error message (E06) is returned.

\* The return “R<CR>” refers only to checking for an argument number. The player is incapable of verifying the existence of a button with this command.

Execution :

String	Status Return	DVD-V7300D
256384ET<CR>	R<CR>	Emulates the “right” click at the point (256,384) on the screen

### 6.39 Get Information (DVD)

Function : Gets the disc information

Format : Integer GI

Explanation : The command, combined with a 4-digit ID and a 4-digit Sub-ID, returns the requested information to the player.

<b>ID (000 X<sub>1</sub>)</b>	<b>Sub-ID (00 Y<sub>1</sub> Y<sub>2</sub>)</b>	<b>Return Data from the Player</b>
0000	Any number	E06 (argument error)
0001	0000 to 0023	System Parameter Info (4-digit)
0001	More than 0023	E06 (argument error)
00002 or more	Any number	E06 (argument error)

The player only returns system parameter information in cases where ID = 0001, otherwise the player returns error message E06.

Below is the simple list of the (SPRM) System Parameter. For more detailed information, refer to "Table 4.6.1.2-1: System Parameters (SPRMs) in DVD Specifications for Read-Only Disc, Part 3 VIDEO SPECIFICATIONS.

<b>SPRM</b>	<b>Explanation</b>
0	Menu Description Language Code (M_LCD)
1	Audio stream number (ASTN) for TT_DOM
2	Sub-picture stream number (SPSTN) & TT_DOM On/Off flag
3	Angle number (AGLN) for TT_DOM
4	Title number (TTN) for TT_DOM
5	VTS Title number (VTS_TTN) for TT_DOM
6	Title PGC number (TT_PGCN) for TT_DOM
7	Part_of_Title number (PTTN) for One_Sequential_PGC_Title
8	Highlighted Button number (HL_BTNN) for Selection state
9	Navigation Timer (NV_TMR)
10	TT_PGCN for NV_TMR
11	Player Audio Mixing Mode (P_AMXMD) for Karaoke
12	Country Code (CTY_LVL) for Parental Management
13	Parental Level (PTL_LVL)
14	Player Configuration (P_CFG) for Video
15	P_CFG for Audio
16	Initial Language Code (INI_LCD) for AST
17	INI_LCD_EXT for AST
18	INI_LCD for SPST
19	(INI_LCD_EXT) Initial Language Code extension for SPST
20	Player Region Code
21	reserved
22	reserved
23	reserved for extended playback mode

For example

SPRM(8): Highlighted Button number (HL\_BTNN) for Selection state

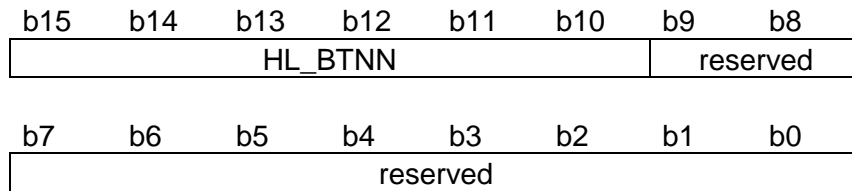

HL_BTNN..... 1 to 36:	HL_BTNN value
Others:	reserved

Execution :

String	Status Return	DVD-V7300D
00010008GI<CR>	1400<CR>	Selecting button #5 now

## 6.40 Memory Data Upload

Function : Reads the data from internal memory in a player:

Format : MU

Explanation : The player sends the data to the computer after the command while it is only Park mode. It is 18,302bytes total. 2,044bytes data that is composed of Condition, Last memory (SETUP, ADV.SETUP, Error History, Program area, etc.), and 16,252 bytes data such as Blackboard and Barcode data, Those both information can be read with the command at the same time.

The Communication flows as shown below.

(N=18,302)

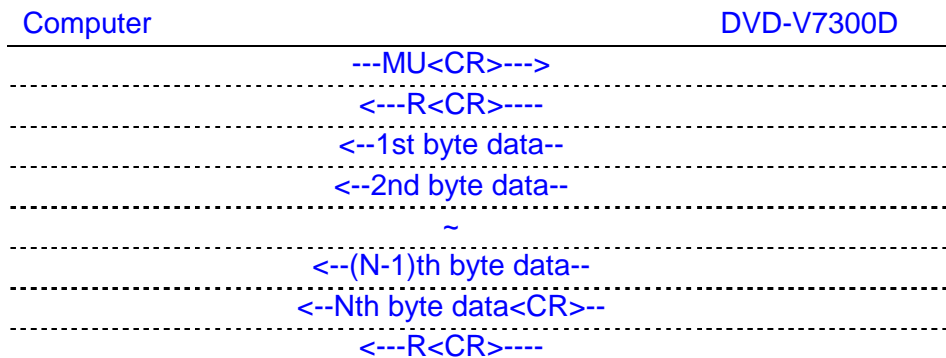

Format of the data:

B P	C O N T E N T S	Number of byte
0 – 1	(1) Total number of the transfer data (fix: 477EH)	2 bytes
2 – 5	(2) 00000000(fix)	4 bytes
6 – 9	(3) Player ID (501558XX) ※1	4 bytes
10 – 16253	(4) Blackboard/Barcode data and Menu selected memory data	16244 bytes
16254 – 16277	(6) LD/VCD last memory data	24 bytes
16278 – 16401	(7) Setup data Error History (date & time): BP=16282 ~32 Bytes Error History (the number of times): BP=16314 ~8Bytes Error History (status) BP=16389 ~8Bytes	124 bytes
16402 – 17429	(8) DVD condition and last memory Power On time BP=16802 ~4Bytes Playback time BP=16806~4Bytes	1028 bytes
17430 – 18297	(9) Programming data	868 byte
18298 – 18301	(10) Checksum	4 bytes

※1 : The player ID:XX is 01 for firmware Version1.016, :02 for Version1.036

Execution :

String	Status Return	DVD-V7300D
		Park mode
MU<CR>	R<CR> ...(18,302 bytes)...<CR> R<CR>	Receives the command and starts the transfer of the data, 18,302 bytes (ends with <CR>)

## 7. OPERATING MODES

The Operating or Active mode consists of five sub-modes; Open, Park, Setup, Random Access and Reject. A command causes the player to change from one sub-mode to another. The five sub-modes are described below.

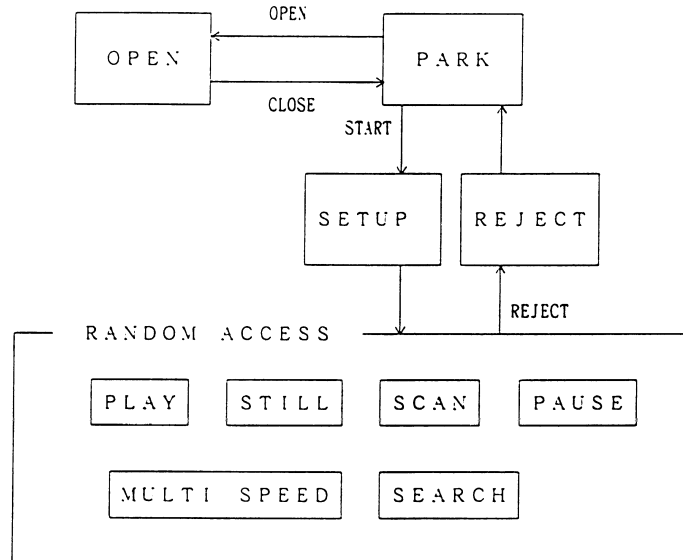

### 7.1 Open

The disc tray is open.

### 7.2 Park

The player enters the Park mode when the tray is closed.

### 7.3 Setup

If the Start command is sent while a disc is in the player, the disc spins up and the player proceeds with the Setup mode.

### 7.4 Random Access

The player enters the Random Access mode when the disc is ready for playback.

The Random Access mode is divided into six sub-modes; Play, Still, Scan, Pause, Multi Speed and Search. Various picture controls in the Random Access mode are available when playing back a DVD or VCD disc. The effects are

achieved through highly-detailed mode transfers. Refer to the previous figure for mode relationship information.

## **7.5 Reject**

When the Reject command is sent to the player, video playback stops. Once the disc rotation has stopped, the player enters the Park mode.

## **8. DVD-V7300D INTERNAL REGISTERS**

When arguments (e.g., Title Number, Chapter Number, Time Code, etc.), accompany commands to the player, argument values are set in the appropriate player registers. This chapter describes each internal register of the player.

### **8.1 Current Time/Frame**

The register contains the current time while a DVD disc is playing; however, the register retains the frame number when a LB-compatible DVD disc (CAV) is running. A CD/VCD disc provides both a current time code and a block number within the register.

### **8.2 P-TIME**

The P-TIME Register contains the elapsed time within a Track or a Chapter.

### **8.3 Current Title/Track (Current Chapter)**

The register contains the current Title/Track Number (Chapter Number).

### **8.4 Current Index**

The register contains the current Index number.

### **8.5 Serial Digit Buffer**

The register contains the command argument values. The commands are placed in a separate, exclusive register.

When the player evaluates a command, the contents of the buffer are transferred to a specified register.

### **8.6 Remote Control Use Address Flag**

When a Search command is sent through the remote control to the player, a flag specifies if the address assigned is a Title/Track, Chapter, Time or Frame.

### **8.7 Remote Control Digit Buffer**

The register contains the numbers input through the remote control.

**8.8 Remote Control Data Register**

The register contains the temporary data input through the remote control.

**8.9 Laser Barcode Buffer**

The register contains the compatible Laser Barcode data transmitted via the remote control.

**8.10 Serial Use Address Flag**

When the Serial Interface controls the player, a flag specifies if the address assigned is a Title/Track, Chapter, Time, Frame, Index, Block or ID.

**8.11 Search Time/Frame**

The register contains a goal Title/Track number (Chapter number) which displays as a frame number, time code or block number.

**8.12 Search Title/Track (Search Chapter)**

The register contains a goal Title/Track number (Chapter number) during a search.

The function is identical to the Search Time/Frame command (ref. 8.11 above).

**8.13 Search Index**

The register contains a goal Index number during a search.

The function is identical to the Search Time/Frame command (ref 8.11 above).

**8.14 Mark Time/Frame**

The register contains a marker (representing the frame number, time code or block number) which indicates the end point of an Auto Play.

When the player performs an Auto Play, the contents of the Mark Time/Frame and the Current Time/Frame are compared.

### **8.15 Mark Title/Track (Mark Chapter)**

The register contains the Title/Track (mark chapter) as a marker.

The function is identical to the Mark Time/Frame command (ref 8.14 above).

### **8.16 Mark Index**

The register contains the Index number as a marker.

The function is identical to the Mark Time/Frame command (ref 8.14 above).

### **8.17 Video Control**

The player uses the register to control the Video ON/OFF switch.

### **8.18 Audio Control**

The player uses the register to select the audio output.

### **8.19 Display Control**

The player uses the register to control the Character Display ON/OFF switch.

The Character Display tracks on-screen information such as time/frame number, title/track number, etc.

### **8.20 Registers**

There are three (3) registers, A B and C. The registers are reserved exclusively for CPU internal operations.

DVD-V7300D Internal Registers

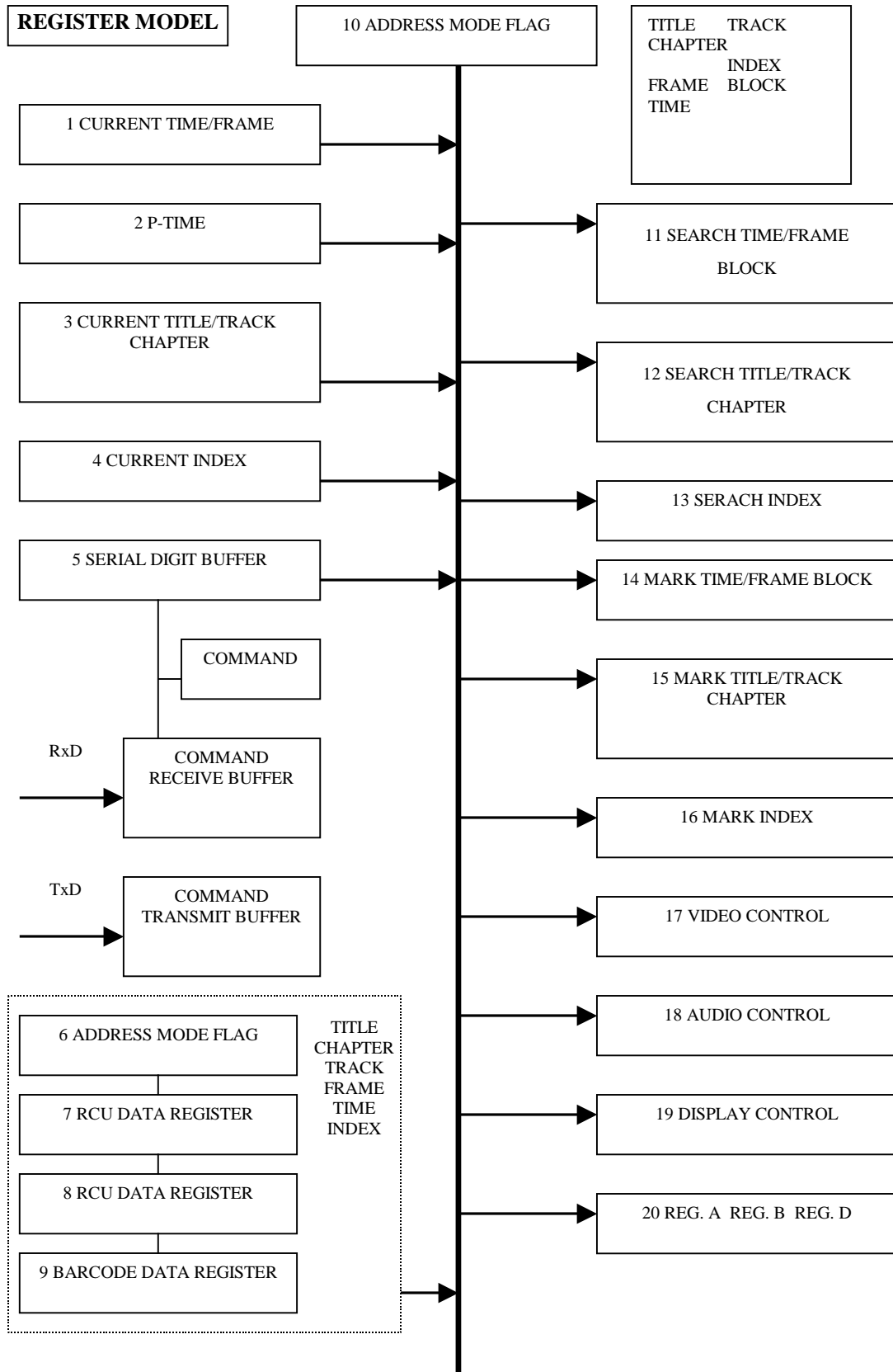

## 9. EXTERNAL SWITCH CONTROL

To control the player through the Serial Interface Connector, use a switching circuit with pins terminated to a +5 volts DC / internal 20,000 ohms resistor.

To activate a function, create a switch contact with an electrical ground (Pin 1). Check Chapter 2 to verify pin (Pin 6 through Pin 13) and terminal (SW1 ~ SW8) assignments.

### 9.1 Function Assignment

External option switch functions(commands) can be subdivided into 3 categories.

#### 1. CALL UP the barcode/command stack group

Function's STACK GROUP's 1-27 can be accessed by the remote control. Press MEMORY key +ENTER(BARCODE/COMMAND) to start the registered COMMAND STACK.

#### 2. Same functions as those on remote control

(↑ ↓ ←→, ENTER, PLAY, STOP, PAUSE, STEP FORWARD, STEP REVERSE, SCAN FORWARD, SCAN REVERSE, SKIP FORWARD, SKIP REVERSE, DISPLAY, RECALL, MEMORY, REPEAT, REPEAT a-b, AUDIO, ANGLE, SUBTITLE, MENU, TOP MENU, SETUP, 0-9, >10, CLEAR RETURN, TITLE/CHP/FRM/TIME)

However, SCAN FWD/REV differs from the remote control, lacking SCAN LOCK(FORWARD SCAN/REVERSE SCAN continue after switch is unpressed)

#### 3. Extensions of the remote control keys

- ↗ ↘ ↙ ↖ Function keys(For diagonal movement in Video Blackboard mode)
- Functions 10-20(direct assignment up to function 20 during SEARCH and MENU selection)
- OPEN/CLOSE function

Create a Circuit Controller or a Diode Matrix Circuit. Refer to the table below for assistance.

Diode Assignment List

	sw1	sw2	sw3	sw4	sw5	sw6	sw7	Sw8	
No.	↑	↓	←	→	ENTER	X	Y	Z	ファンクション
※ 1	1								↑
※ 2		1							↓
※ 3			1						←
※ 4				1					→
※ 5					1				ENTER
※ 6						1			STACK GROUP1
※ 7							1		STACK GROUP2
※ 8								1	STACK GROUP3
9	1			1					↗
10		1		1					↘
11		1	1						↙
12	1		1						↖

## DVD-V7300D Internal Registers

13					1	1			PLAY	
14					1		1		STOP	
15					1			1	PAUSE	
16					1	1	1		STEP FORWARD	
17					1	1		1	STEP REVERSE	
18					1		1	1	RETURN	
19	1	1							OPEN/CLOSE	
20			1	1					DISPLAY	
21	1	1	1						SCAN FORWARD	
22	1	1		1					SCAN REVERSE	
23	1		1	1					SKIP FORWARD	
24		1	1	1					SKIP REVERSE	
※	25	1				1			1	
※	26		1			1			2	
※	27			1		1			3	
※	28				1	1			4	
		sw1	Sw2	sw3	sw4	sw5	Sw6	Sw7	Sw8	
	No.	↑	↓	←	→	ENTER	X	Y	Z	
※	29	1						1		5
※	30		1					1		6
	31			1				1		7
	32				1			1		8
	33	1							1	9
	34		1						1	10
	35			1					1	11
	36				1				1	12
	37	1	1				1			13
	38	1		1			1			14
	39	1			1		1			15
	40		1	1			1			16
	41		1		1		1			17
	42			1	1		1			18
	43	1					1	1		19
	44		1				1	1		20
※	45			1			1	1		STACK GROUP4
※	46				1		1	1		STACK GROUP5
※	47	1	1					1		STACK GROUP6
	48	1		1				1		STACK GROUP7
	49	1			1			1		STACK GROUP8
	50		1	1				1		STACK GROUP9
	51		1		1			1		STACK GROUP10
	52			1	1			1		STACK GROUP11
	53	1						1	1	STACK GROUP12
	54		1					1	1	STACK GROUP13
	55			1				1	1	STACK GROUP14
	56				1			1	1	STACK GROUP15
	57	1	1						1	STACK GROUP16

58	1		1				1	STACK GROUP17	
59	1			1			1	STACK GROUP18	
60		1	1				1	STACK GROUP19	
61		1		1			1	STACK GROUP20	
62			1	1			1	STACK GROUP21	
63	1					1	1	STACK GROUP22	
64		1				1	1	STACK GROUP23	
65			1			1	1	STACK GROUP24	
66				1		1	1	STACK GROUP25	
67						1	1	STACK GROUP26	
68						1	1	STACK GROUP27	
※	69						1	1	TOP MENU
※	70					1	1	1	MENU
	71	1				1	1		RECALL
	72	1				1		1	SETUP
	73	1				1		1	MEMORY
	74		1			1	1		>10
	75		1			1		1	REPEAT
	76		1			1		1	REPEAT A-B
	77			1		1	1		AUDIO
	78			1		1		1	ANGLE
	79			1		1		1	SUBTITLE
	80				1	1	1		TITLE/CHP/FRM/TIME
	81				1	1		1	0
	82				1	1		1	CLEAR

※ In accordance with the ADV Setup's External OPTION SW setting, when a limit is assigned, only the marked switches are available

## 9.2 Controller

Examples of Switch and Diode specifications are charted below.

### Switch Specifications

On Resistance	Less than 1 ohm
Off Resistance	More than 1 M ohm
Type	Non-Locking

### Diode Specifications

Forward Voltage Drop (VF)	Less than 0.7 (IF 1ma)
Surge Forward Current (IFSM)	Less than 100ma
Forward Current	Less than 10μa

**9.2.1 Simple Circu**

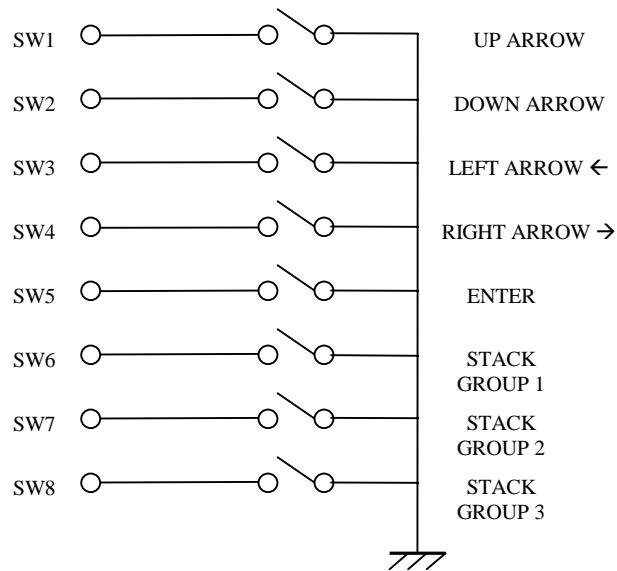

**9.2.2 Diode Matrix Circuit**

In this case, up to 82 switches may be assigned

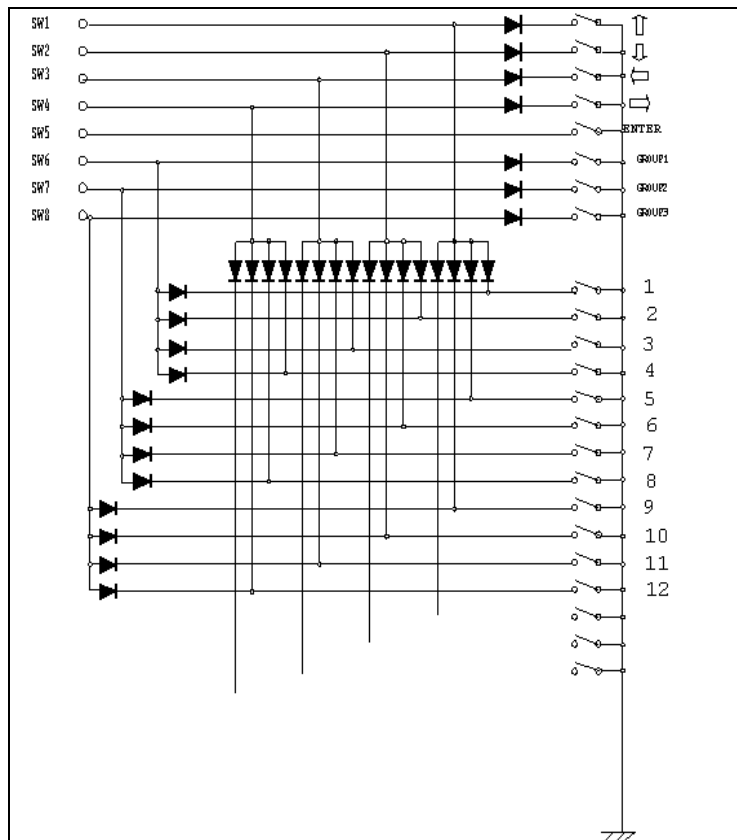

# **DVD-V7300D**

---

---

## **Industrial DVD Player RS-232 Command Protocol**

Pioneer Electronic Corporation

4-1, Meguro 1-chome

Meguro-ku, Tokyo 153

JAPAN

<http://www.pioneer.co.jp>